

Fuses

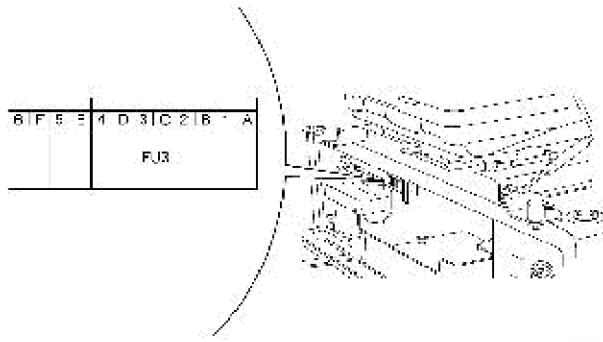

Figure 3

- FU3/10 A 2-speeds, attachment carrier, variable track, accessories

Travel operation

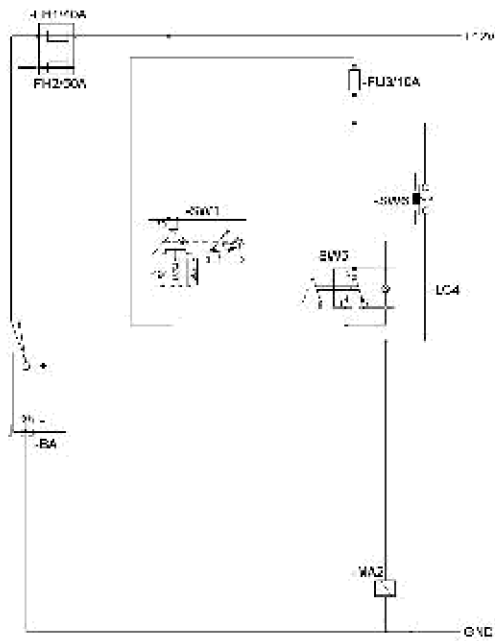
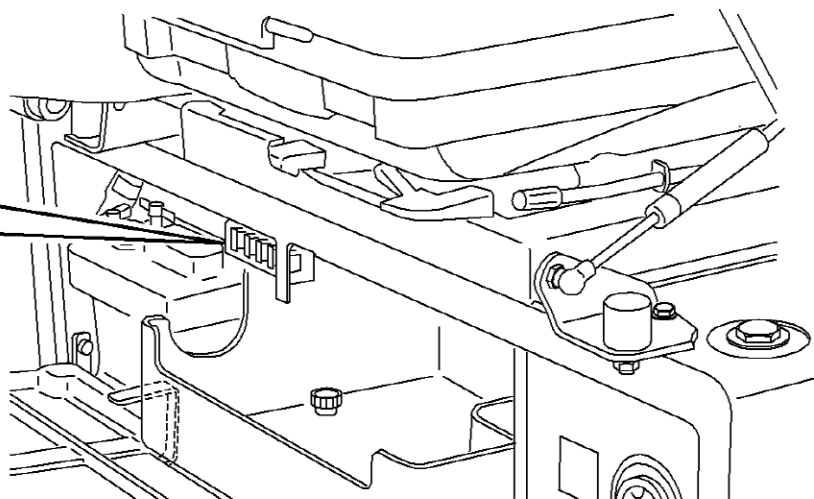
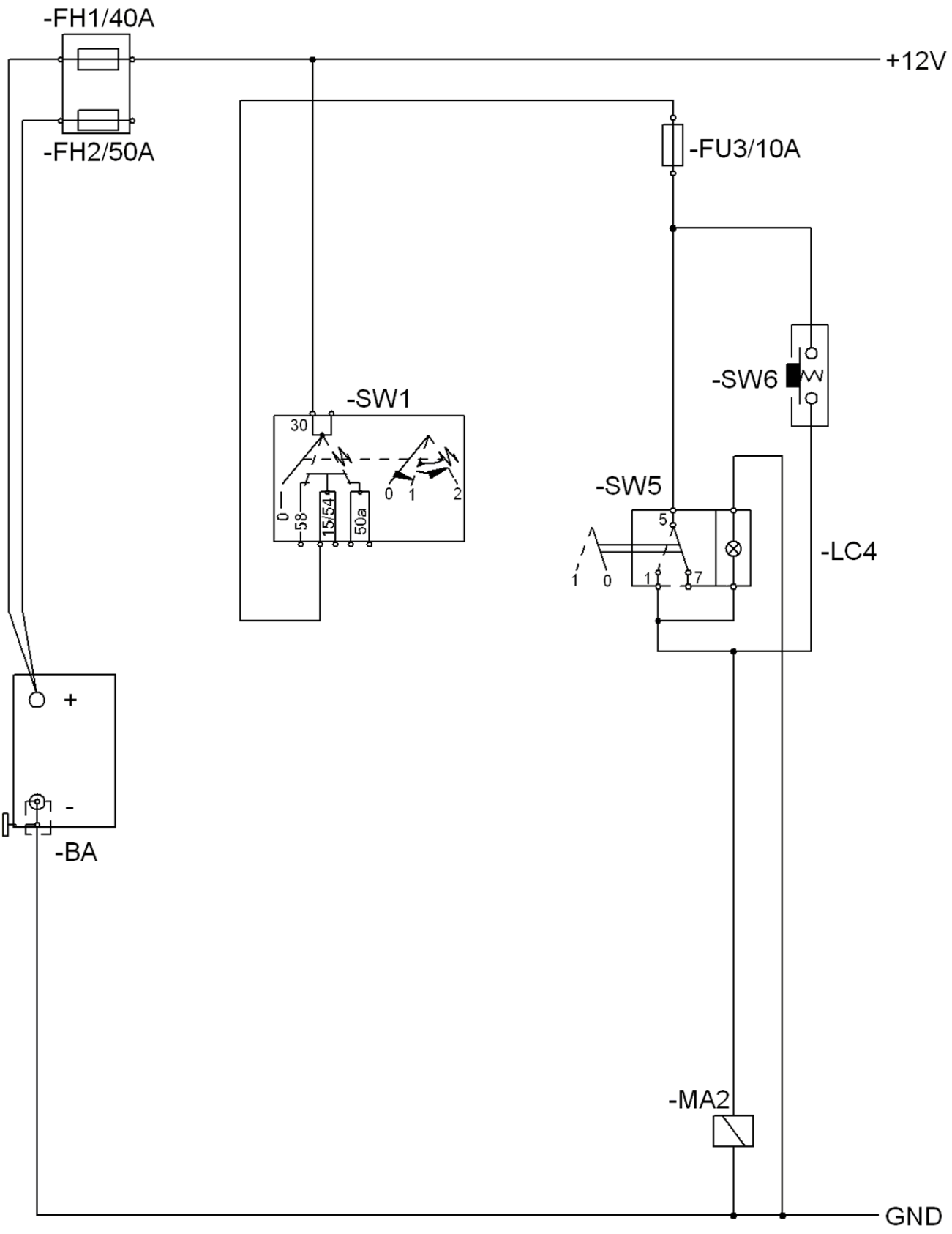

Figure 4

6	F	5	E	4	D	3	C	2	B	1	A
						FU3					





VOLVO

Construction Equipment

PROSIS Service Information

Document Title : Variable track (only XTV design)	Function Group : 300	Information Type : Service Information	Print Date : 19/10/2011
Profile : CEX, EC15B XTV (Volvo) [GB]			

Variable track (only XTV design)

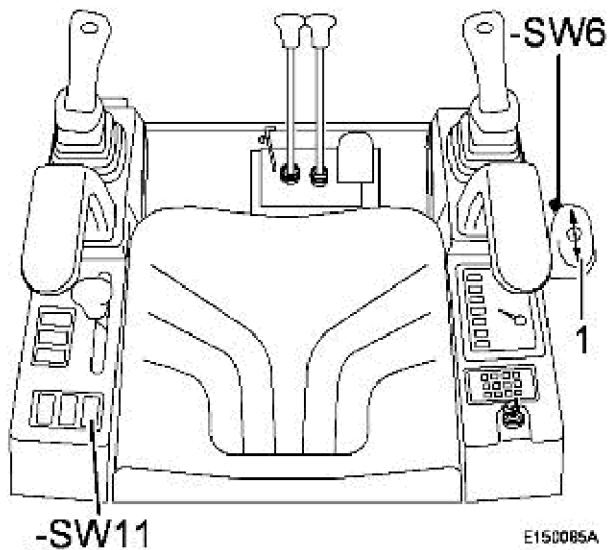

Figure 1

- 1 Control lever, variable track
- SW6 Push button, variable track
- SW11 Switch, variable track

Changing the track width:

- Switch on selector switch - SW11 .
- Hold push button - SW6 depressed and change the track with control lever 1 (forw./back).

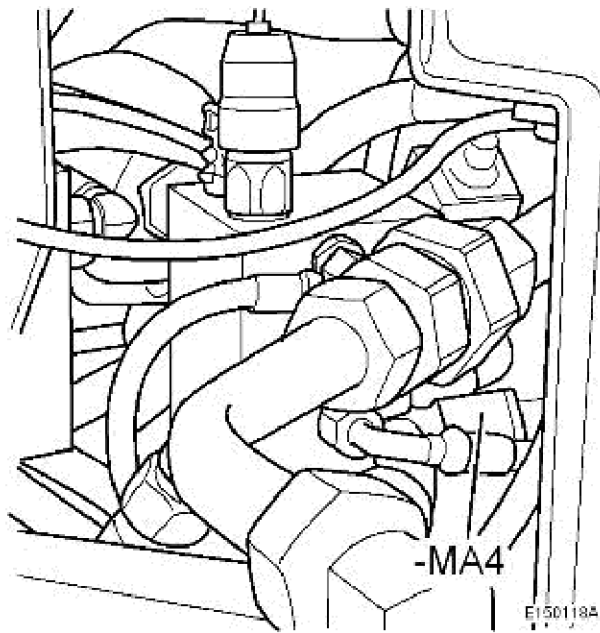

Figure 2

- MA4 Solenoid valve, variable track width

The solenoid valve - MA4 is located in the driver's cab under the floor plate on the left hand side.

Fuses

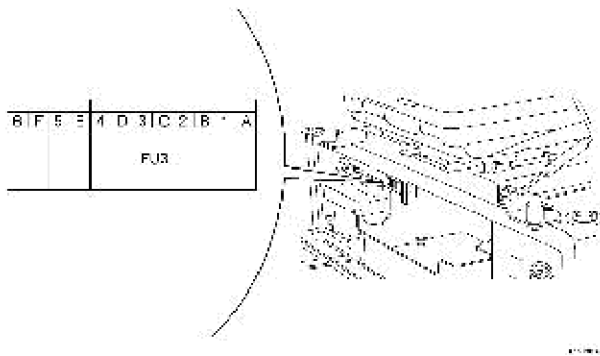
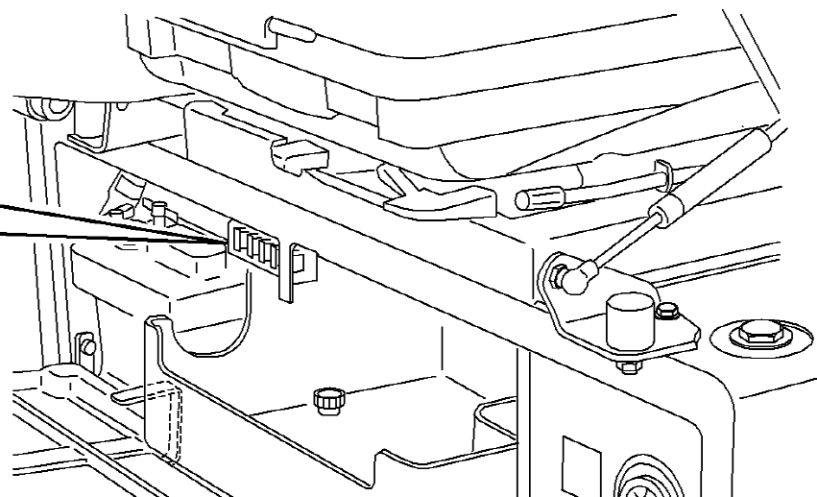
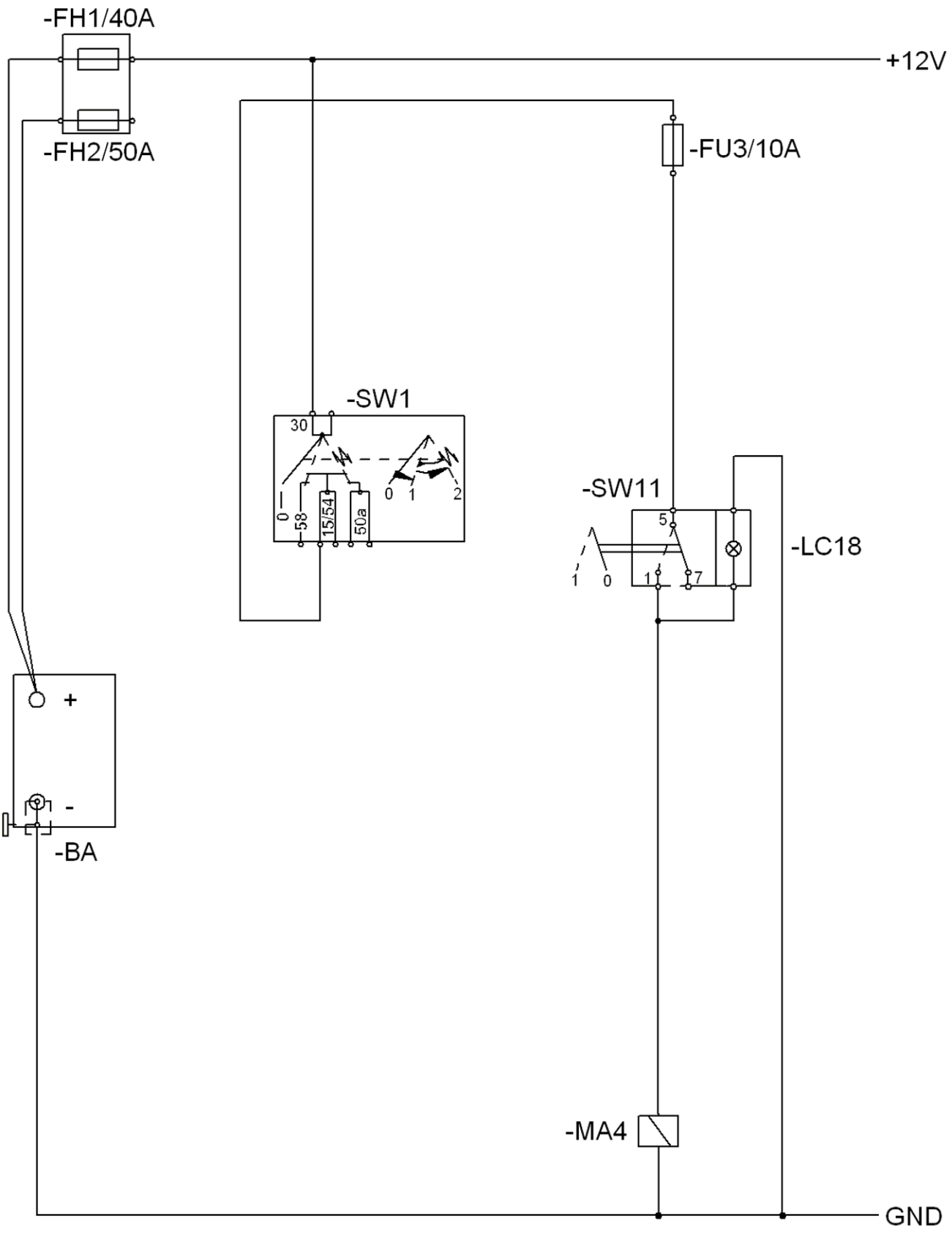

Figure 3

- FU3/10 A 2-speeds, attachment carrier, variable track, accessories

6	F	5	E	4	D	3	C	2	B	1	A
						FU3					







Construction Equipment

PROSIS Service Information

Document Title : Slewing/offsetting	Function Group : 300	Information Type : Service Information	Print Date : 19/10/2011
Profile : CEX, EC15B XTV (Volvo) [GB]			

Slewing/offsetting

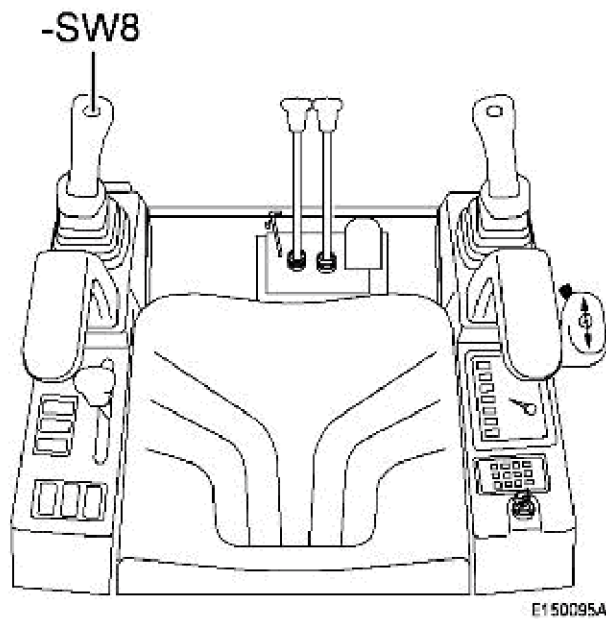

Figure 1

- SW8 Switch for slewing/offsetting

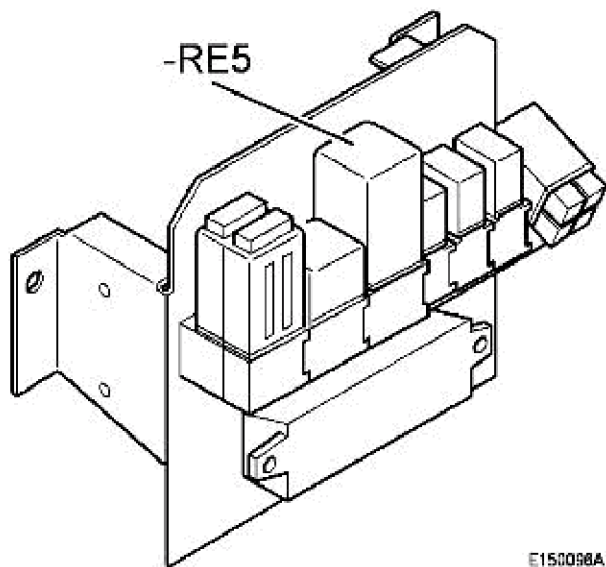

Figure 2

- RE5 Relay for slewing/offsetting

Fuses

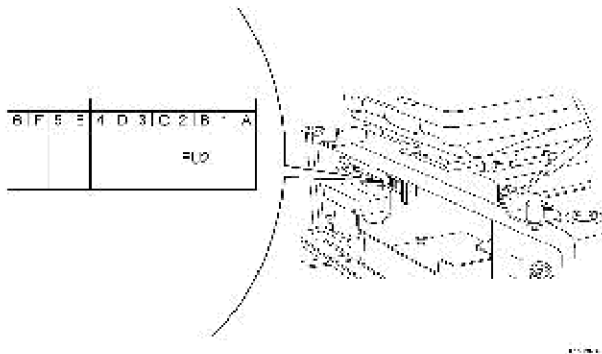

Figure 3

- FU2/10 A Lock Slewing/offset, hydraulic support, safe starting

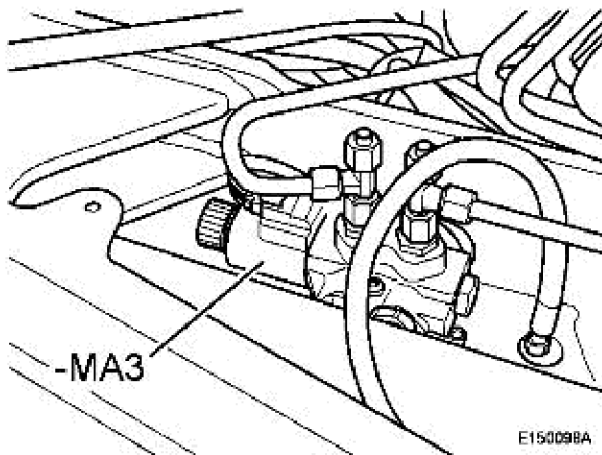

Figure 4

- MA3 Solenoid valve, slewing/offsetting

The solenoid valve - MA3 is located in the driver's cab under the floor plate at the front right hand side.

Slewing/offsetting

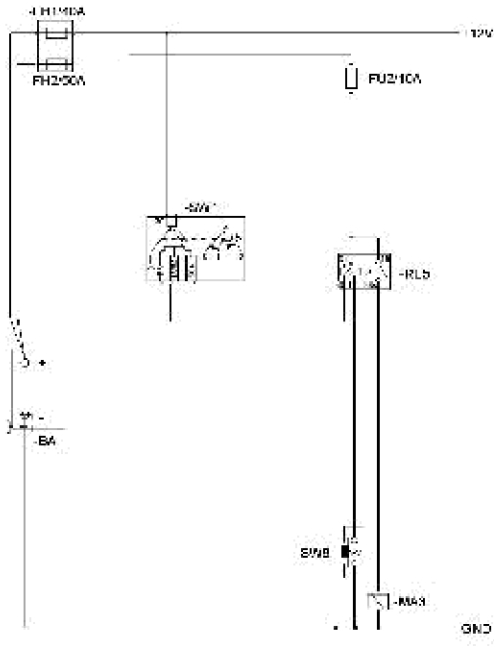
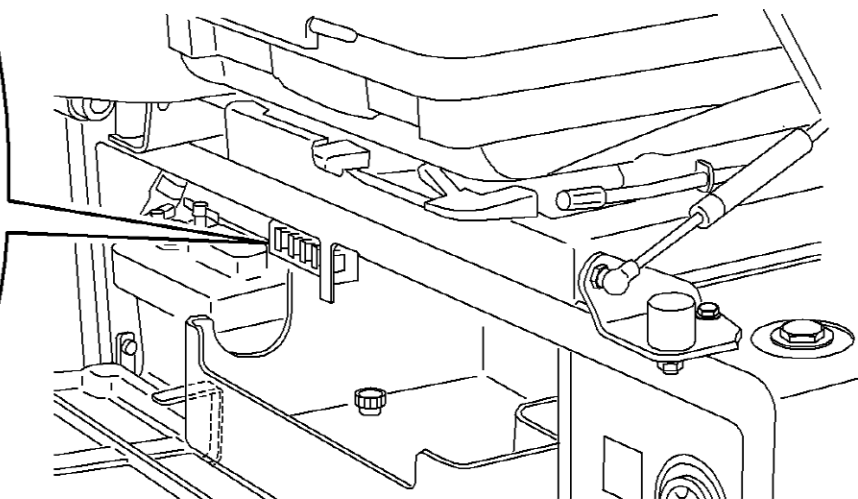
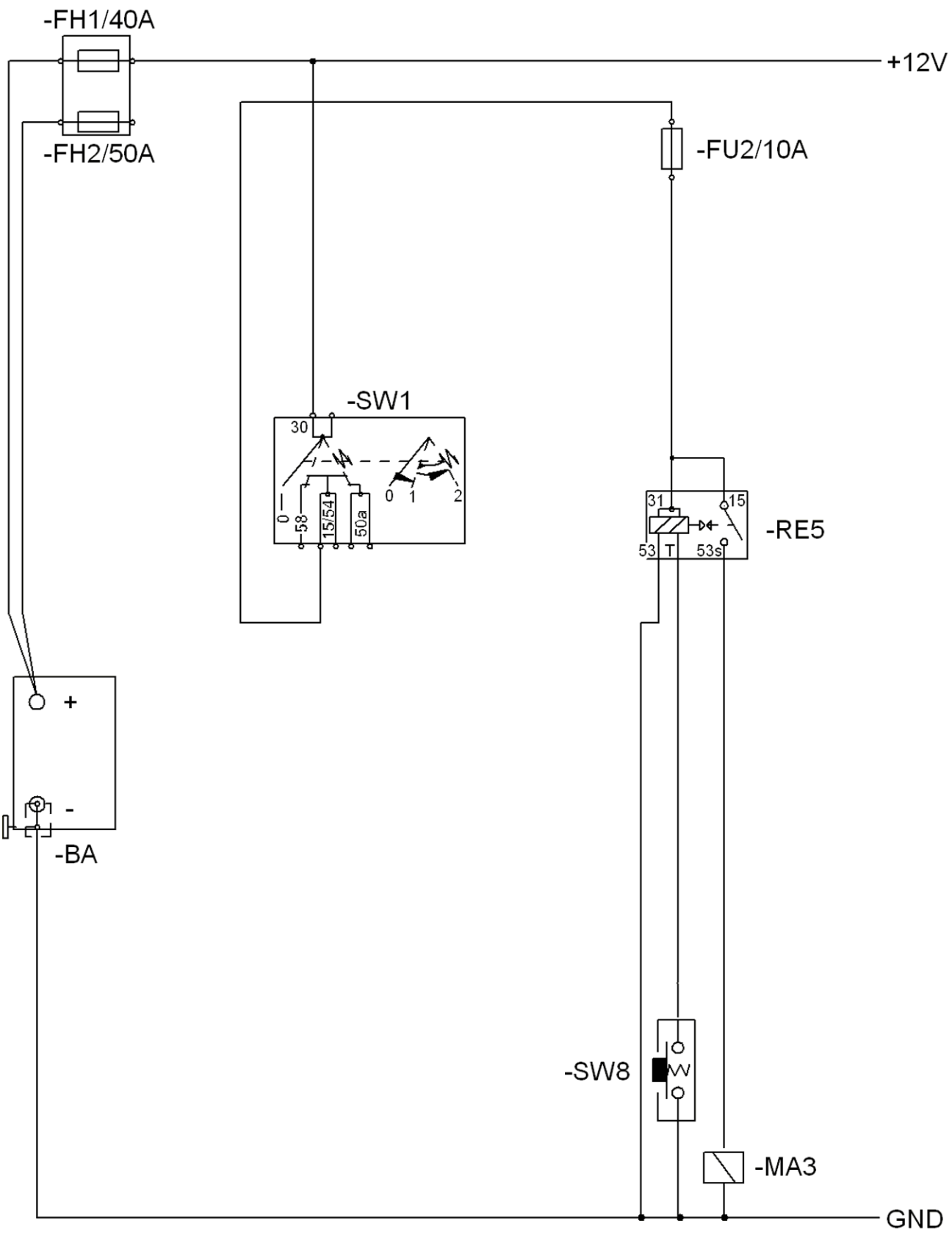

Figure 5

6	F	5	E	4	D	3	C	2	B	1	A
									FU2		





VOLVO

Construction Equipment

PROSIS Service Information

Document Title : Battery, description	Function Group : 310	Information Type : Service Information	Print Date : 19/10/2011
Profile : CEX, EC15B XTV (Volvo) [GB]			

Battery, description

- The battery delivers a voltage of 12 Volt.
- The battery is used to start the engine, to supply the electrical components with electric current and to store the current supplied by the generator.

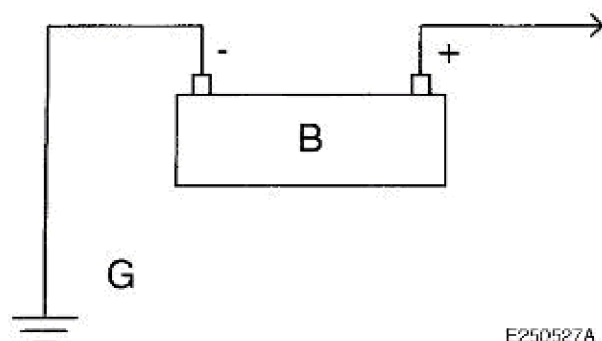

Figure 1
Battery

- B Battery
- G Ground

**WARNING!**

Battery acid can cause cauterization of the skin and blindness. If your skin or eyes have come in contact with battery acid rinse off immediately with lots of clear water and consult a physician.

Caution!

If a tool comes in contact with the positive terminal of the cable and, at the same time, with the chassis, there is a risk of formation of sparks.

The pole clamps must be properly tightened, as otherwise there is a risk that the connections may burn or corrode because of the parts caused by insufficient contact.

When removing the battery you should first disconnect the black sheathed cable from the ground connection (negative (-) pole).

NOTE

Under very cold weather conditions the battery power may drop. In this case warm up the battery and start the engine.



Construction Equipment

PROSIS Service Information

Document Title : Battery, specification	Function Group : 310	Information Type : Service Information	Print Date : 19/10/2011
Profile : CEX, EC15B XTV (Volvo) [GB]			

Battery, specification

Item		Unit	Specification
Battery	Type	-	MF
	Power	V-Ah	12-44
	Quantity	EA	1



Construction Equipment

PROSIS Service Information

Document Title : Tests before disassembly	Function Group : 320	Information Type : Service Information	Print Date : 19/10/2011
Profile : CEX, EC15B XTV (Volvo) [GB]			

Tests before disassembly

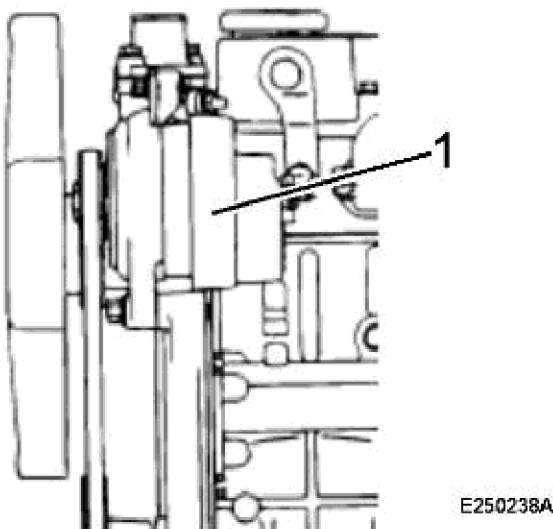
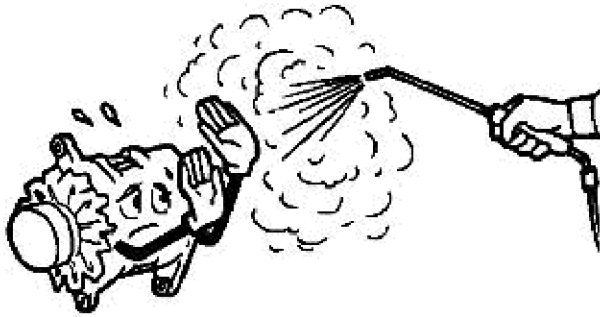

Figure 1
Generator on engine

Prerequisite for a correct diagnose of the load circuit is a thorough examination while the generator is still mounted to the engine, in order to be able to decide whether the generator needs to be removed for more thorough testing. The following table, which describes two faults and always four possible reasons, helps to detect the cause of the fault:

Load on generator too high	Voltage regulator set too high
	Ground line defective
	Wiring faulty
	Series resistor or winding in open electrical circuit
Generator does not deliver any load	Generator drive belt loose
	Voltage regulator set too low
	Low generator power
	Brushes worn off



E250239A

Figure 2

Precautions for disassembly

Essential precautions for disassembly are listed below:

1. When connecting the battery make sure that the ground line is connected.
2. Do not use a mega-ohmmeter (meter for high resistance values of electrical equipment).
3. Disconnect the battery cables before starting to charge the battery.
4. Do not attempt to disconnect the cable coming from terminal B on the generator while the engine is running.
5. The battery voltage is applied to terminal B of the Generator, not connected to ground.
6. Do not short or ground terminal L of the generator to the integrated CI-regulator.
7. The generator must not come in contact with the jet of a steam cleaner.



Construction Equipment

PROSIS Service Information

Document Title : Generator	Function Group : 320	Information Type : Service Information	Print Date : 19/10/2011
Profile : CEX, EC15B XTV (Volvo) [GB]			

Generator

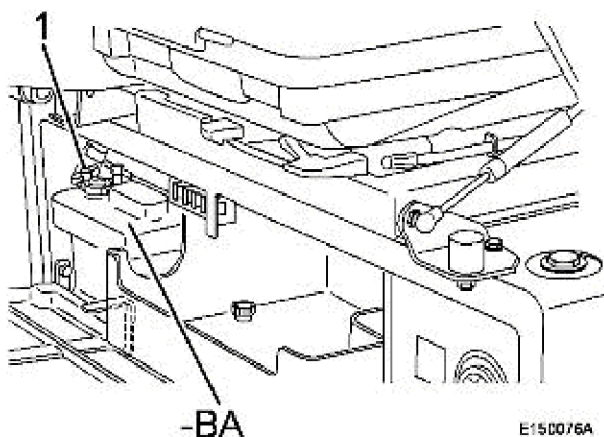

Figure 1

- BA Battery
- 1 Battery disconnect terminal

The batteries are located under the driver's seat, on the right hand side.

The dual covers of the battery are fitted with acid mist separators.

In case of a fault in the electrical system, e.g. regulator fault, compensate the increased water consumption of the battery.

x

WARNING!

Observe the safety regulations

The battery disconnecting terminal ([See figure/1](#)) is located on the minus pole.

In case of longer periods of standstill the battery disconnecting terminal must be disconnected from the battery.

x

WARNING!

The main battery switch must not be switched off while the engine is running. The generator must be connected with the battery while the engine is running. Non-compliance with the prerequisites mentioned above may cause damage to the generator.

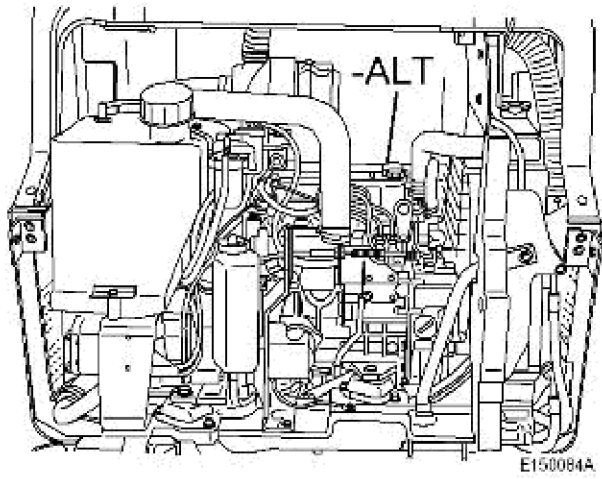

Figure 2

- ALT Generator
Generator

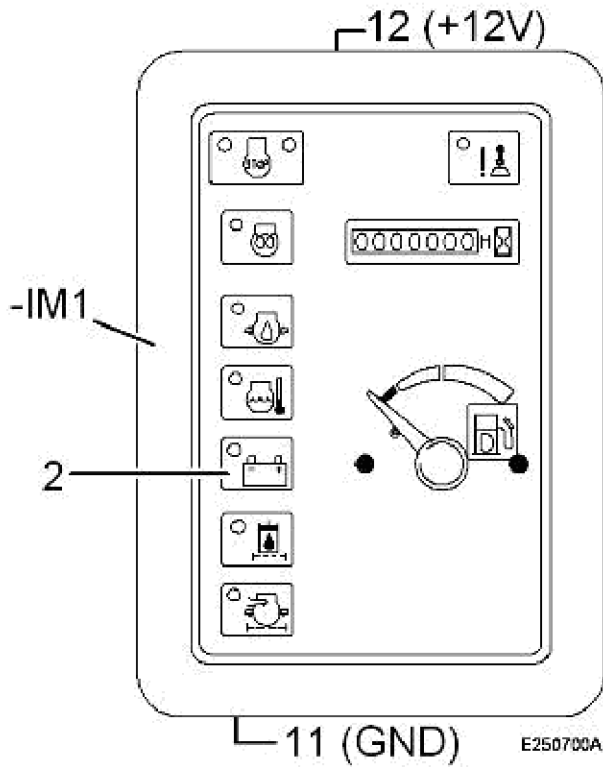

Figure 3

2 Battery charge condition gauge
Dashboard (- IM1)

Fuses

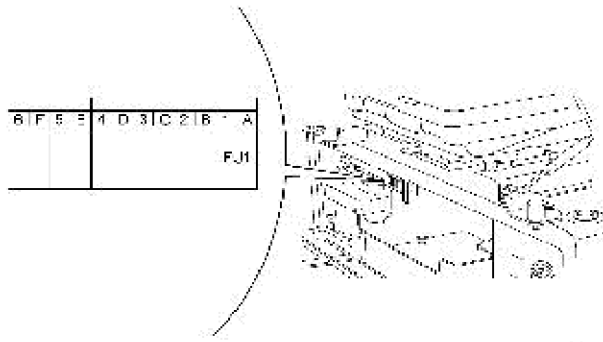

Figure 4

- FU1/5 A Engine, dashboard, immobilizer

Power supply

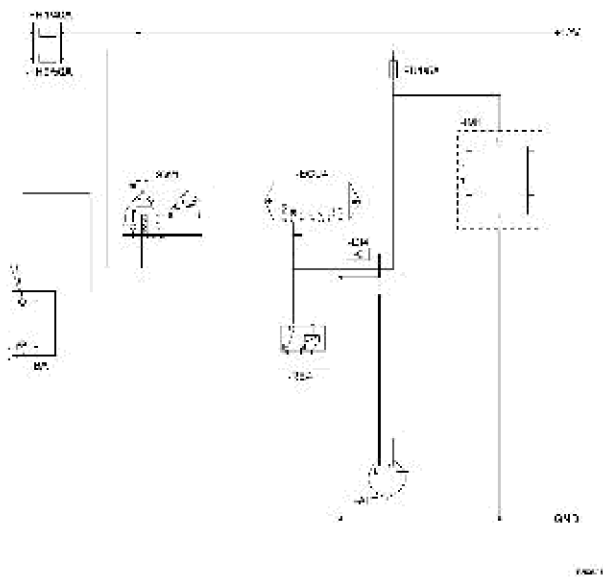
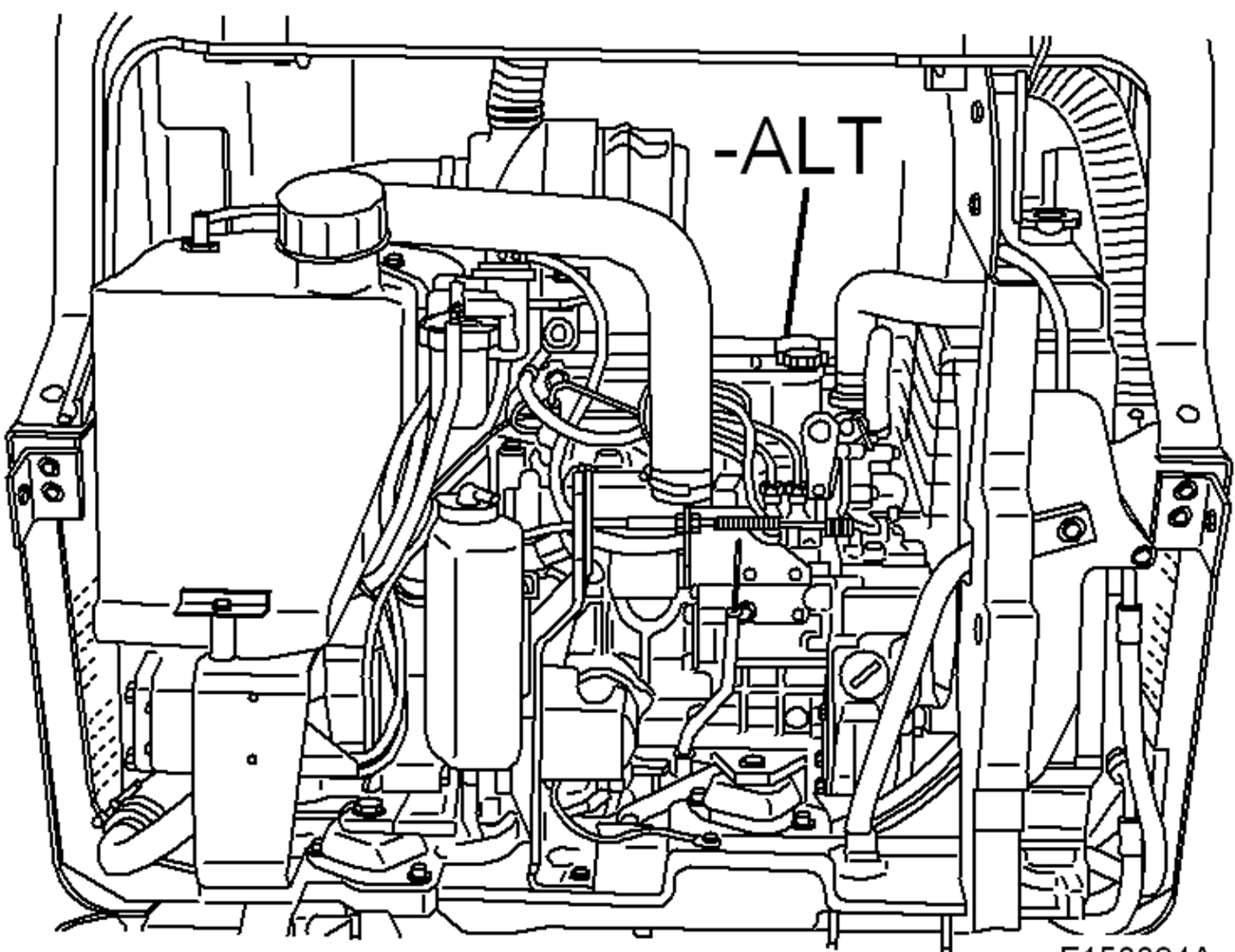
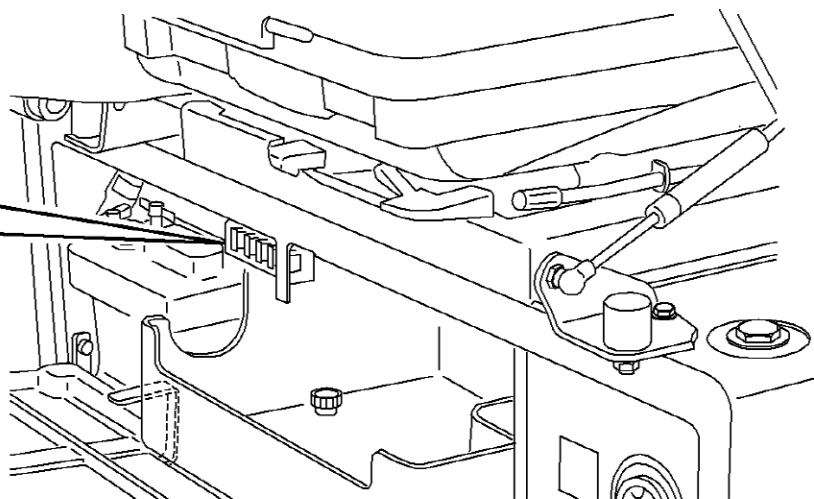

Figure 5



E150084A

6	F	5	E	4	D	3	C	2	B	1	A
											FU1



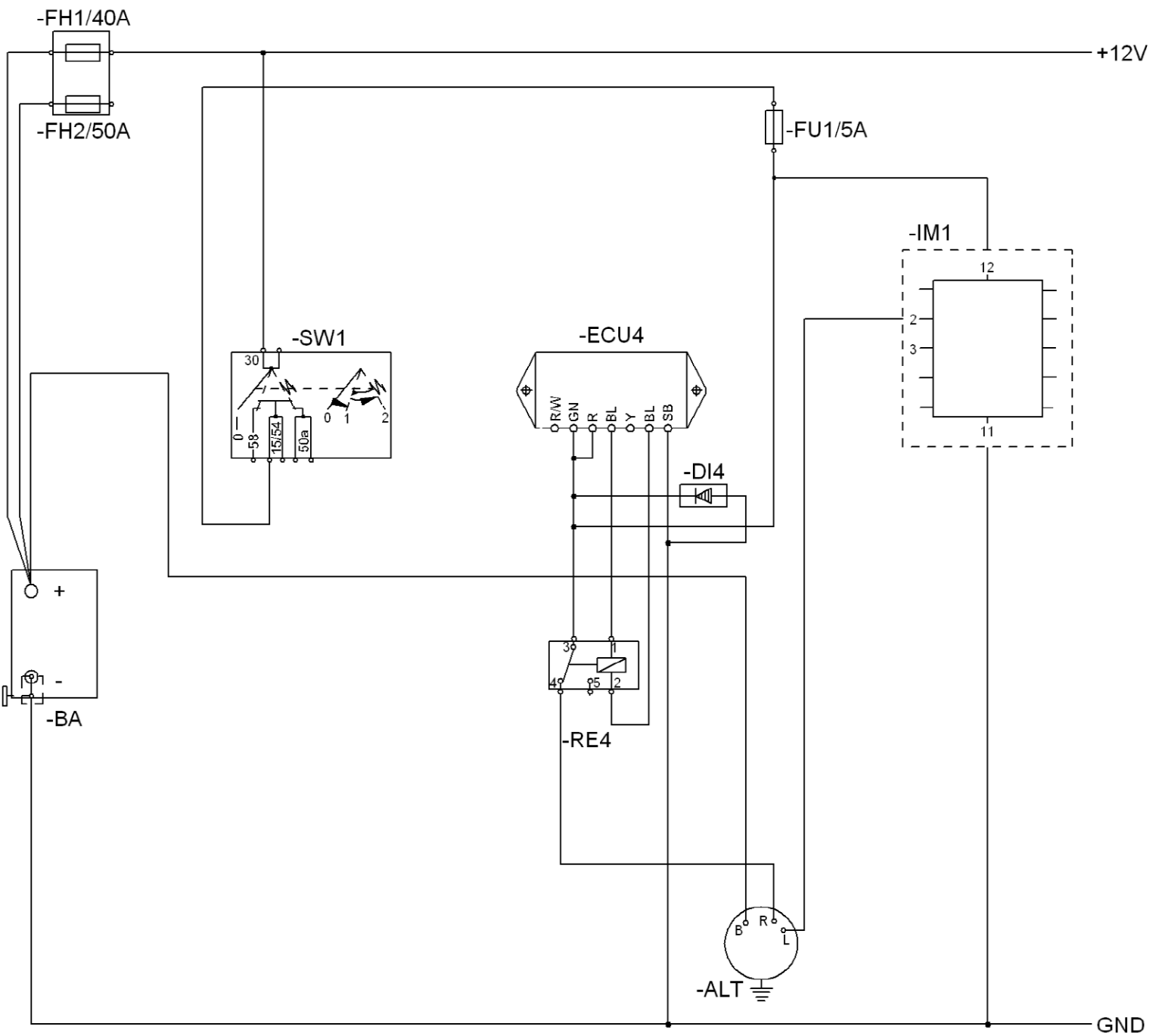

VOLVO

Construction Equipment

PROSIS Service Information

Document Title : Removing the generator	Function Group : 321	Information Type : Service Information	Print Date : 19/10/2011
Profile : CEX, EC15B XTV (Volvo) [GB]			

Removing the generator

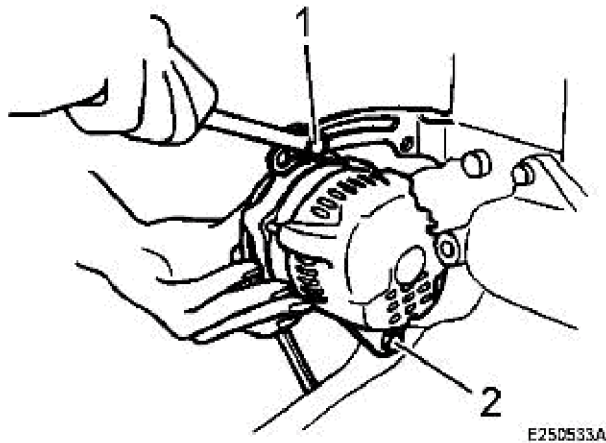

Figure 1
Removing the generator

Op nbr 321



- Disconnect the battery cables.
- Disconnect the cable from terminal B of the generator.
- Pull cable connections of the generator.
- Loosen screw (1) and the bolt of the carrier element (2). Push the generator towards the engine and take off the drive belt.
- Remove the generator.

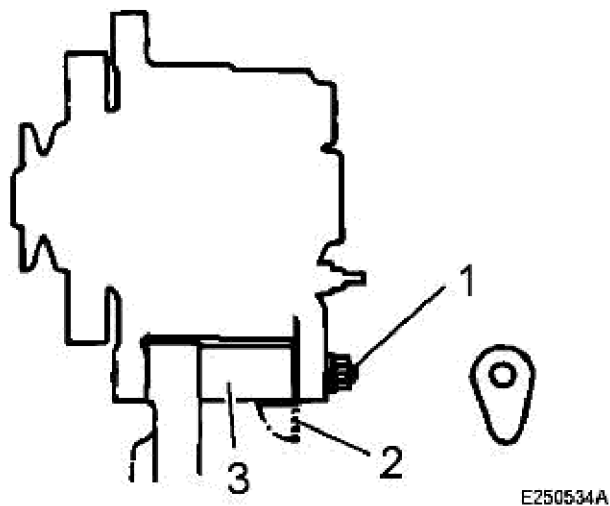

Figure 2
Installation of the generator

- 1. Screw bolt
- 2. Intermediate stay
- 3. Spacer piece

Installing the generator

Op nbr 321



- Position the generator. Attach the bolt of the adjustment plate with which the generator is fastened.
- Place the belt on the pulley. Press the generator away from the engine and adjust the belt.
- Tighten the bolts.
- With correct V-belt tension it should be possible to compress the V-belt with high force for approx. 12 mm.
- Connect terminal B.
- Plug on the cable connector.

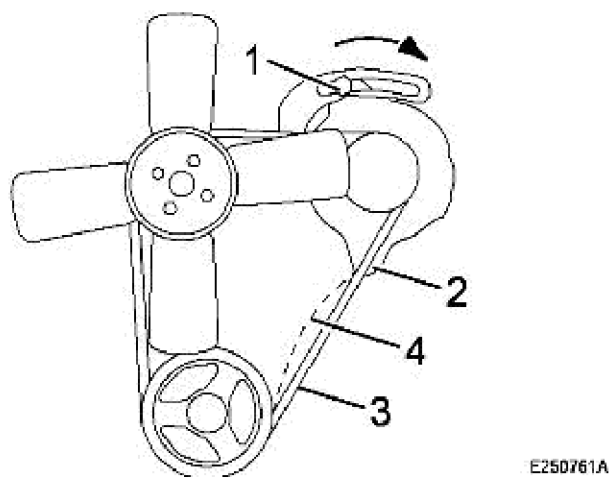

Figure 3
Tensioning the V-belt

- 1. Screw
- 2. Screw bolt
- 3. V-belt
- 4. Tightness test 12 mm



Construction Equipment

PROSIS Service Information

Document Title : Dismantling and assembling the generator	Function Group : 321	Information Type : Service Information	Print Date : 19/10/2011
Profile : CEX, EC15B XTV (Volvo) [GB]			

Dismantling and assembling the generator

Generator specification

Op nbr

[Ohmmeter](#)

Designation	AOT25171
Regulator, type	AOT25371
Rated power, V - A	IC
	12-40

Disassembly

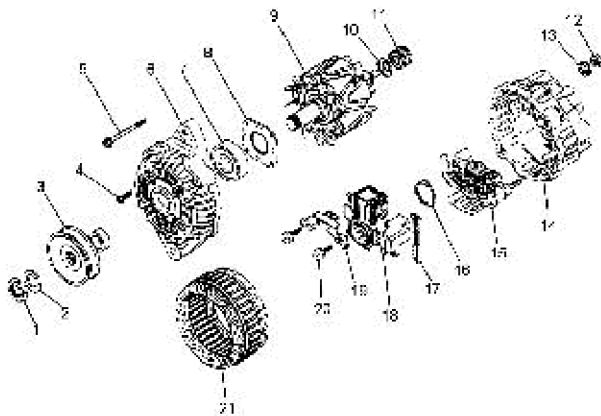

Figure 1
Generator disassembled

- | | | |
|-------------------------|-------------------------|----------------|
| 1 Nut | 11 Rear roller bearing | 21 Stator core |
| 2 Washer | 12 Nut | |
| 3 V-belt pulley | 13 Washer | |
| 4 Screw | 14 Rear carrier element | |
| 5 Screw | 15 Rectifier | |
| 6 Front carrier element | 16 Washer | |
| 7 Front roller bearing | 17 Brushes | |
| 8 Roller bearing guard | 18 Brush holder | |
| 9 Rotor | 19 Bracket | |
| 10 Cover | 20 Screws | |



Construction Equipment

PROSIS Service Information

Document Title : Dismantling and assembling the generator	Function Group : 321	Information Type : Service Information	Print Date : 19/10/2011
Profile : CEX, EC15B XTV (Volvo) [GB]			

Dismantling and assembling the generator

Generator specification

Op nbr

[Ohmmeter](#)

Designation	AOT25171
Regulator, type	AOT25371
Rated power, V - A	IC
	12-40

Disassembly

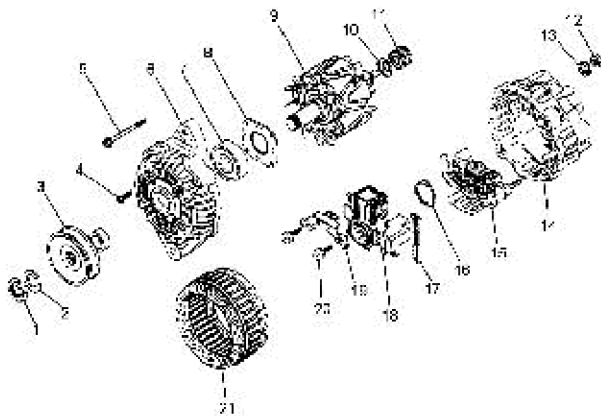
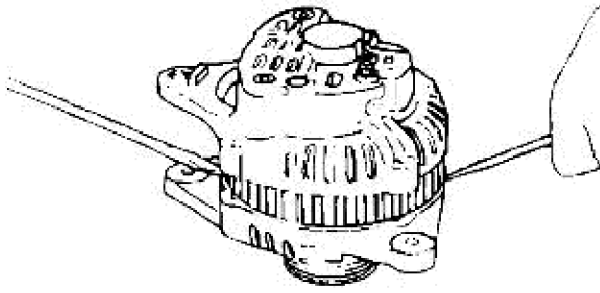

Figure 1
Generator disassembled

- | | | |
|-------------------------|-------------------------|----------------|
| 1 Nut | 11 Rear roller bearing | 21 Stator core |
| 2 Washer | 12 Nut | |
| 3 V-belt pulley | 13 Washer | |
| 4 Screw | 14 Rear carrier element | |
| 5 Screw | 15 Rectifier | |
| 6 Front carrier element | 16 Washer | |
| 7 Front roller bearing | 17 Brushes | |
| 8 Roller bearing guard | 18 Brush holder | |
| 9 Rotor | 19 Bracket | |
| 10 Cover | 20 Screws | |



E250245A

Figure 2
Disassembly of generator

- In order to separate the stator core from the front carrier element lift the core up with a screwdriver, as shown in the illustration.

Caution!

Do not insert the screwdriver too deep in order to prevent the stator core from being damaged.

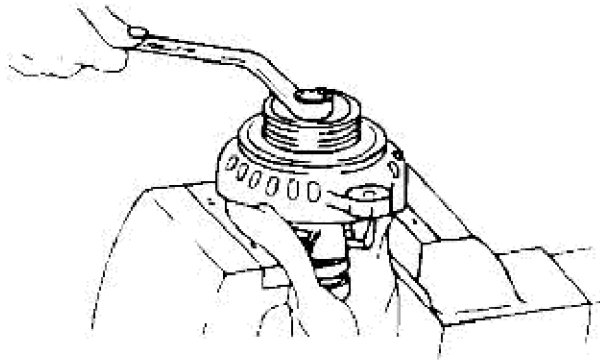

E250246A

Figure 3
Disassembly of the washer

- Clamp the rotor unit in a vice, use a thick cloth to do so, as shown in the illustration. Unscrew the nut retaining the washer, then remove washer and intermediate piece.
- Loosen the rotor unit from the front carrier element.

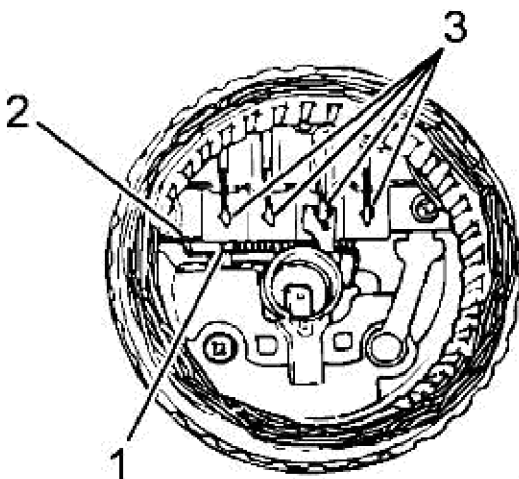

E250247A

Figure 4
Disassembly of the stator core

1. Unsolder the cable
2. Rectifier
3. Unsolder the cable

- De-solder the cables coming from the rectifier and remove the stator.

Caution!

Unsolder the cables as quickly as possible to avoid damaging the rectifier diodes.

- Unscrew the fastening screws for the rectifier and remove the rectifier.
- Check all parts with an ohmmeter as follows:

Diodes on rectifier

Check the resistance between diode and heat sink. First touch the diode with the positive test probe (+) of the ohmmeter and then with the negative test probe (-). If the resistance is infinite in both cases the diode must be open. If the resistance is near zero in both cases, the diode must be closed. Repeat this test on all diodes. If one of the diodes is open or shorted, replace the rectifier.

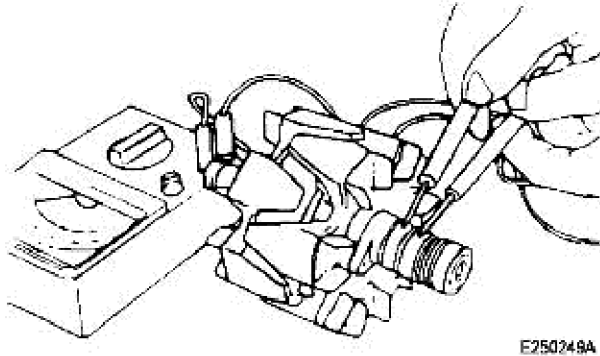

Figure 5
Check the field coil for an open field circuit

Field coil

Check whether current flow between the collector rings is assured (see illustration). If this is not true, there is an open current circuit in the field coil. In this case the complete generator must be replaced.

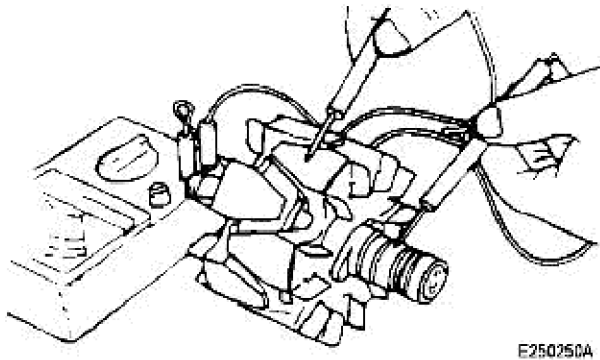
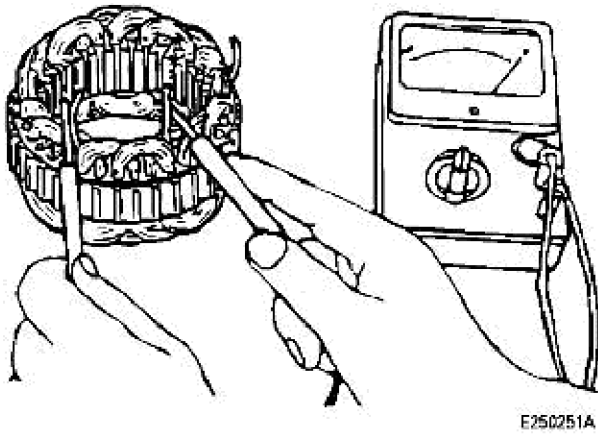

Figure 6
Checking the field coil for a ground circuit

Check whether current flows between collector ring and rod (or core) (see illustration). A current flow indicates the existence a ground circuit in the field coil. In this case the complete generator must be replaced.



E250251A

Figure 7
Check the stator core for an open electric circuit

Stator core

Check whether current flow between the cables is assured (see illustration). If this is not true, there is an open current circuit in the stator core. In this case the complete generator must be replaced.

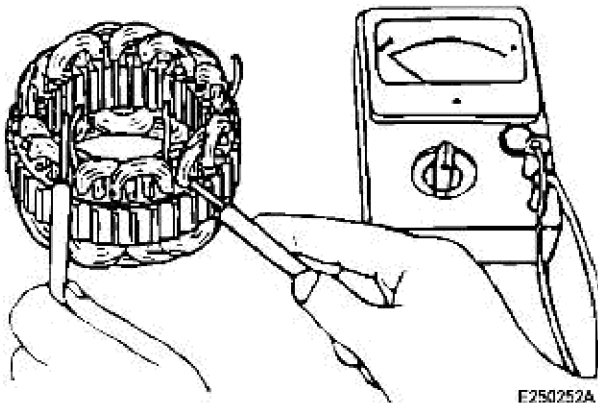

E250252A

Figure 8
Checking the stator core for a ground circuit

Check whether no current flows between each cable and the stator core (see illustration). A current flow indicates the existence a ground circuit in the stator core. In this case the complete generator must be replaced.

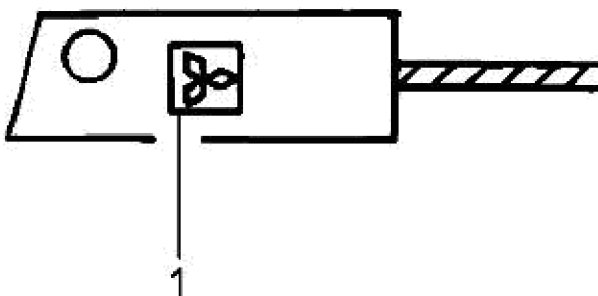

E250253A

Figure 9
Checking the brushes for wear

1. Wear mark
- Replace the brushes if they are worn down to the wear mark.

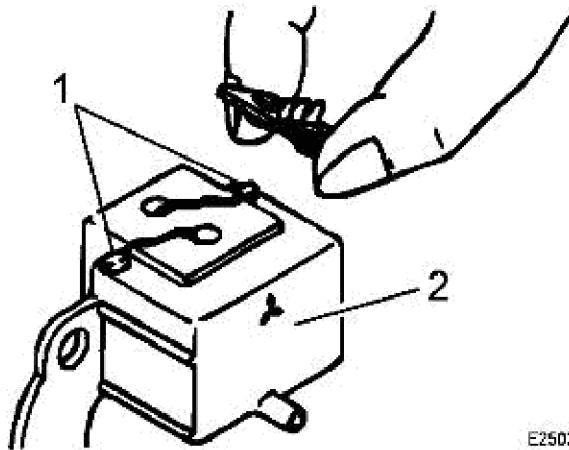

E250254A

Figure 10
Removing the brushes

1. Unsolder the cable
2. Brush holder

- Unsolder the cables from the brushes and remove the brushes with springs.

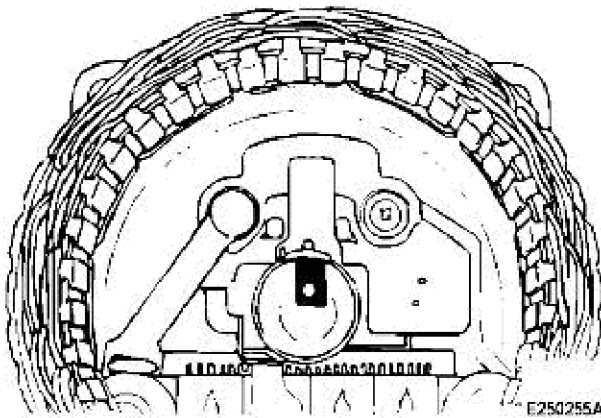

E250255A

Figure 11
Installing the brushes

Assembly

Op nbr



- Insert the brushes into the brush holder and solder the cables to the brushes.

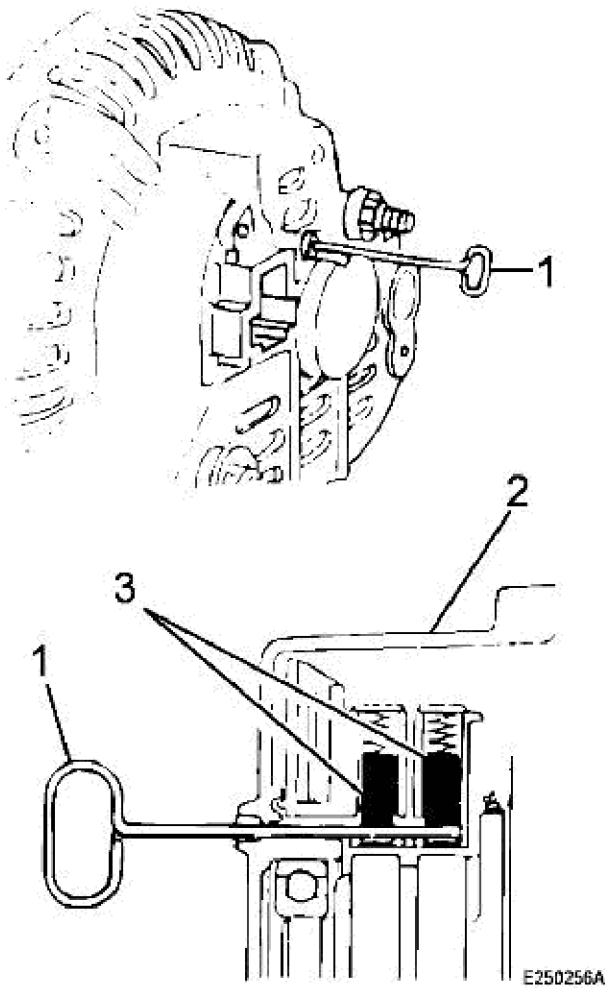
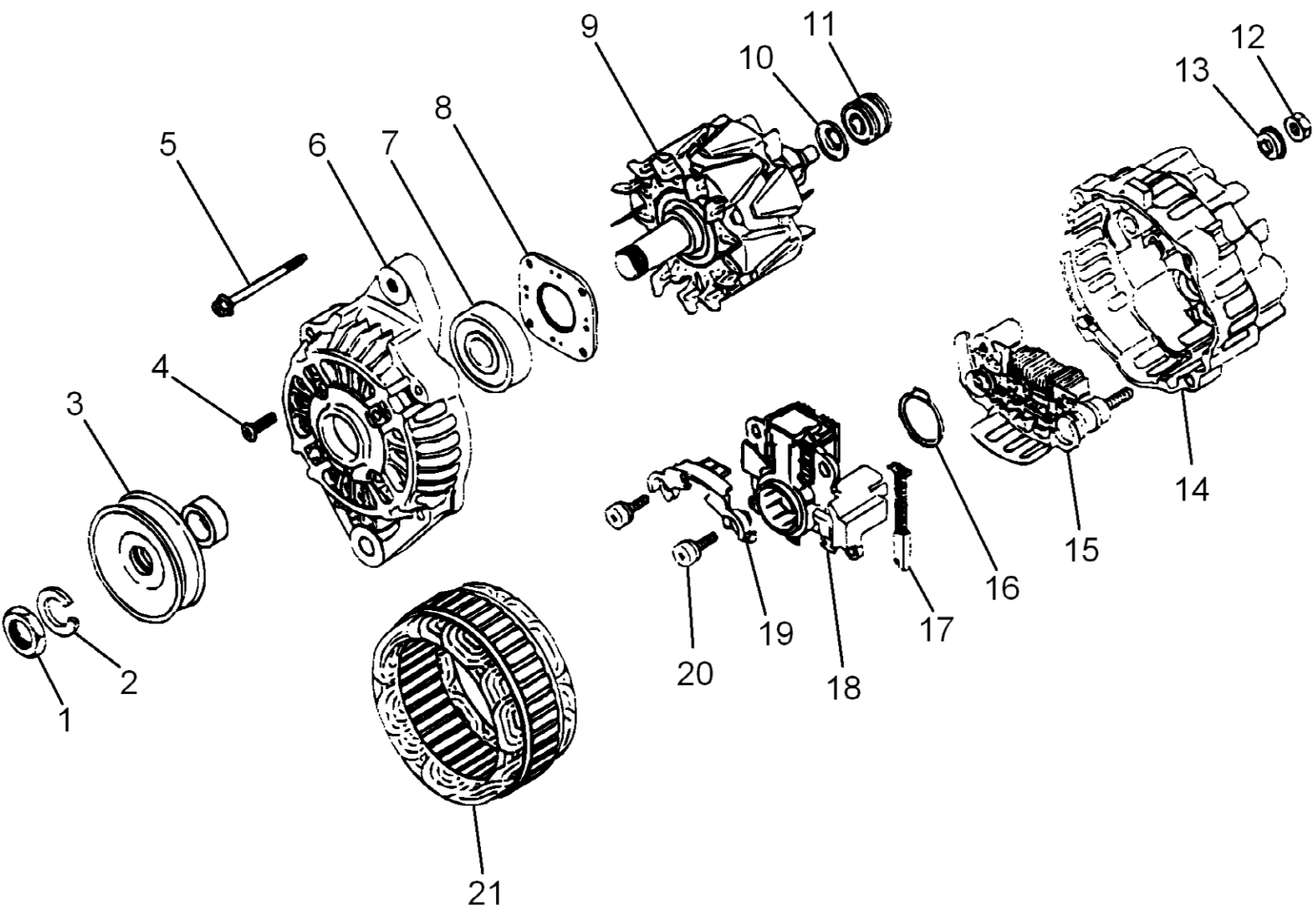

Figure 12
Assembling the generator

1. Wire-type tool
2. Rear carrier element
3. Brushes

Proceed in reverse order to dismantling and use the following method.

- The rear bearing has a groove for the circlip. Install the snap ring into this groove and make sure that its tongue is located in the deeper section of the groove.
- When assembling the new rear bearing align the bearing so that the side with the groove faces towards the circlips.
- For the assembly of the rear bearing heat up the rear carrier element.
- Before installing the rotor into the rear carrier element insert a wire-type tool into the opening of the rear carrier element and loosen the brushes of the collector rings. Once the rotor has been inserted remove the tool.



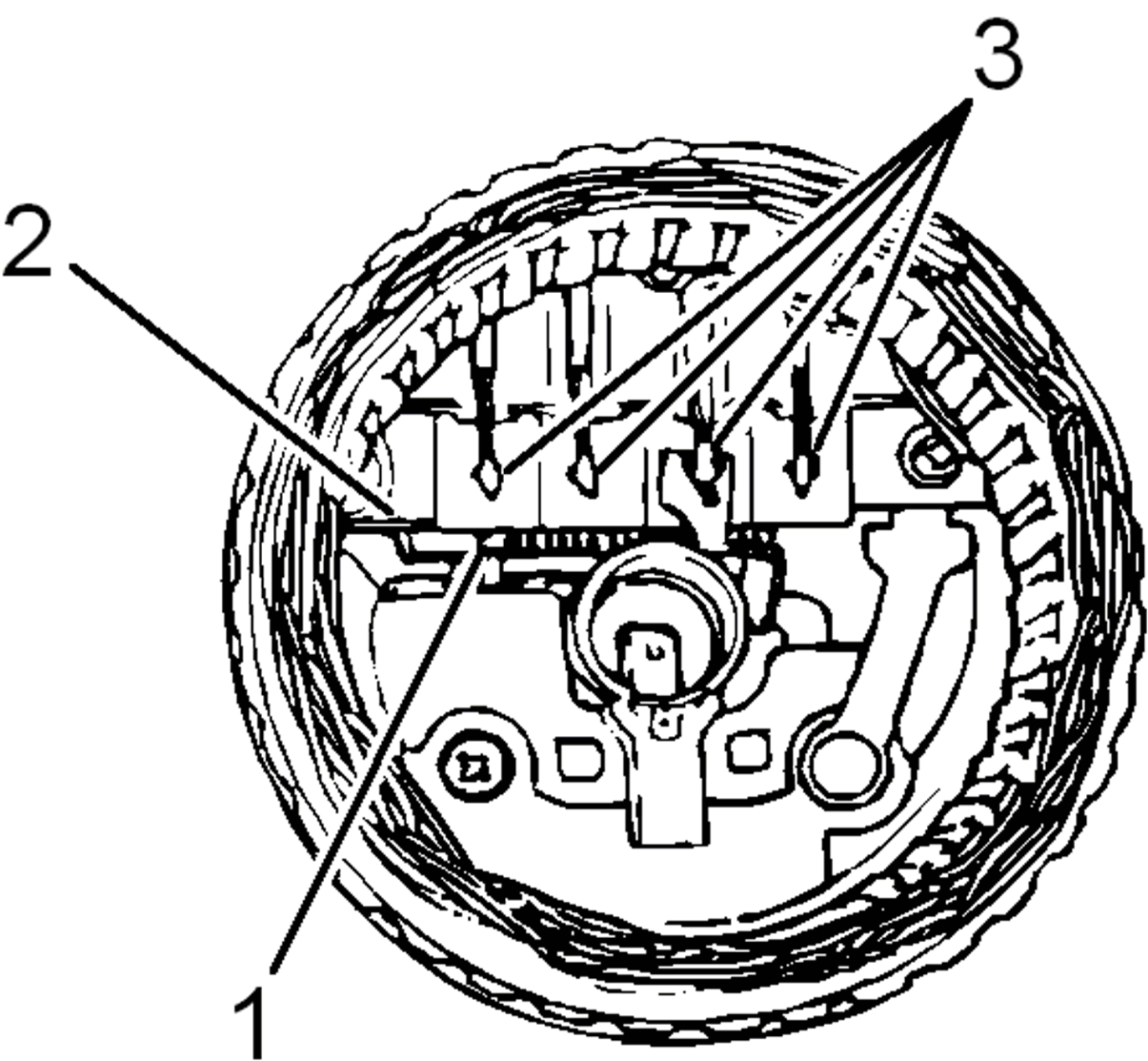

E250247A



Construction Equipment

PROSIS Service Information

Document Title : Checking the voltage regulation	Function Group : 322	Information Type : Service Information	Print Date : 19/10/2011
Profile : CEX, EC15B XTV (Volvo) [GB]			

Checking the voltage regulation

Op nbr

[Ammeter, voltmeter](#)

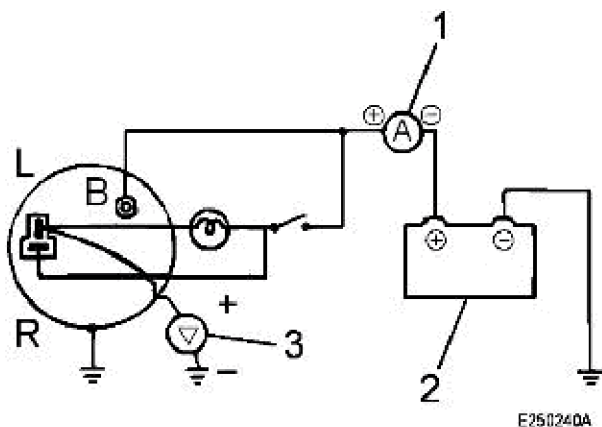

Figure 1
Connections for testing the voltage regulation

1. Ammeter
2. Battery 12 V
3. Voltmeter

Article	Standard
Voltage adjustment at 20 °C	14,7 ± 0.3 V

- Connect the generator to a 12 V battery with ammeter, voltmeter and switch, as shown in the illustration.
- The voltmeter must show (0) when the starting contactor is set to OFF. When the starter contactor is set to ON (the engine cannot be started) the value must be lower than the battery voltage.
- Start the engine, whereby one cable of the ammeter is shorted.
- With all electrical consumers switched off read the voltmeter when the ammeter shows a reading of 5 Ampere and at an engine speed of 1800 and 2500 rpm. The voltage regulation depends on the temperature of the generator. The following is normally valid: The higher the temperature of the generator, the lower the voltage regulation.



Construction Equipment

PROSIS Service Information

Document Title : Checking the performance characteristics	Function Group : 322	Information Type : Service Information	Print Date : 19/10/2011
Profile : CEX, EC15B XTV (Volvo) [GB]			

Checking the performance characteristics

Op nbr

[Ammeter](#)

Performance characteristics, specification

Model	Standard	
	Voltage/amperage on the terminals	Speed
AOT25171	12 V / 40 A	5,200 rev./min, max
AOT25371		

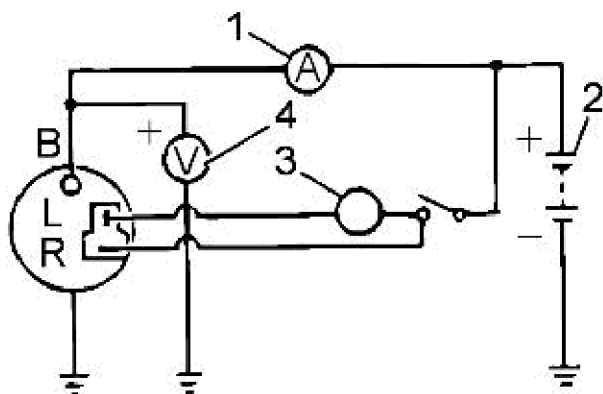

E250241 B

Figure 1
Connections to check the performance characteristics (generator with integrated regulator)

1. Ammeter
 2. Battery
 3. Generator control light
 4. Voltmeter
- Disconnect the ground cable from the battery.
 - Connect one cable of the ammeter with terminal B on the generator and the other one with the plus pole of the battery. Connect one cable of the voltmeter with terminal B and the other one with ground.
 - Connect the battery ground cable.
 - Start the engine.
 - Switch on all electrical consumers.

- Raise the engine speed. When the voltmeter shows a reading of 14 Volt measure the maximum current output at the specified speed of the generator.

VOLVO

Construction Equipment

PROSIS Service Information

Document Title : Starting process	Function Group : 330	Information Type : Service Information	Print Date : 19/10/2011
Profile : CEX, EC15B XTV (Volvo) [GB]			

Starting process

Voltage supply

- The negative pole (-) of the battery is grounded at the engine. When the main switch is in OFF position, the power supply is switched off.

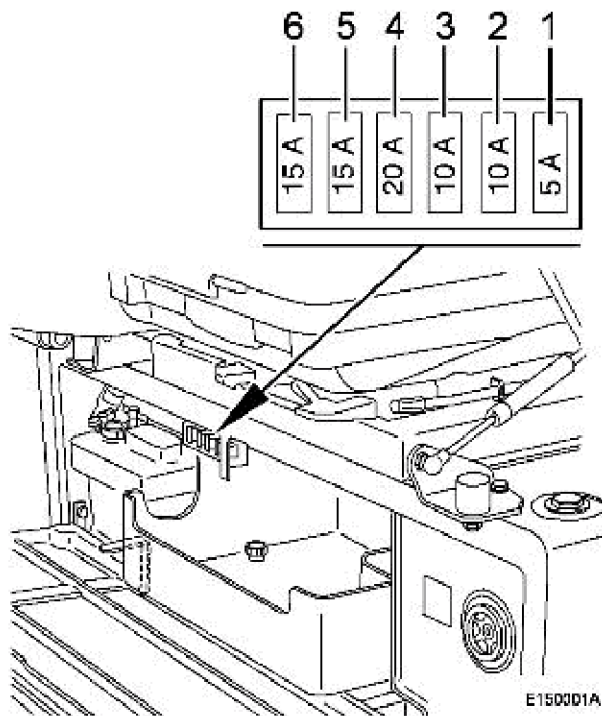
**Figure 1**

When turning the main switch to position ON, current flows to the following electrical circuits if the ignition switch is in position OFF:

- Battery (+) → Starter connection (B⁺) → Battery relay
- Battery (+) → slow blowing fuse (40A)

Fuses:**Machine equipment:**

- 5 A-fuse: Engine safety relay – power supply for control unit – fuel pump.
- 10 A-fuse: Solenoid valve for slewing gear/offset and auxiliary hydraulic system.
- 10 A-fuse: Solenoid valve for two-speed operation and track width adjustment.
- 20 A-fuse: Power supply for cabin – working head lights on boom and cabin.
- 15 A-fuse: Power supply for cabin.
- 15 A-fuse: Flashing beacon – warning horn – connection for hand lamp

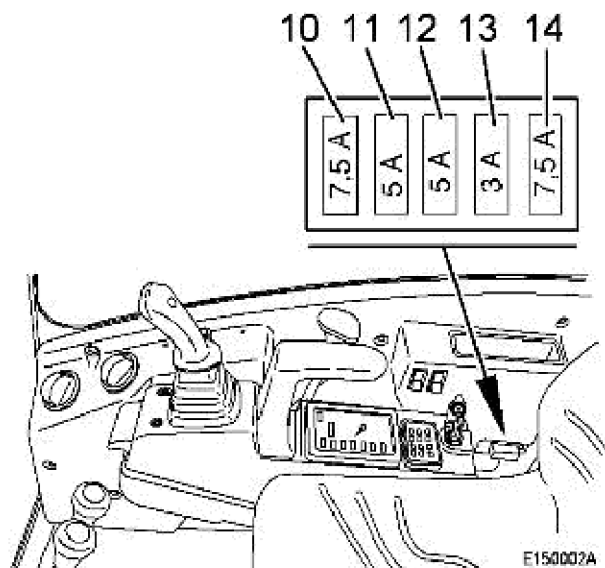

Figure 2

Cabin equipment:

- 10- 7.5 A-fuse: Motor for windscreen wiper and windscreen washer system.
- 11- 5 A-fuse: Cabin lighting.
- 12- 5 A-fuse: Radio
- 13- 3 A-fuse: Radio
- 14- 7.5 A-fuse: Motor for ventilation and cabin heating.

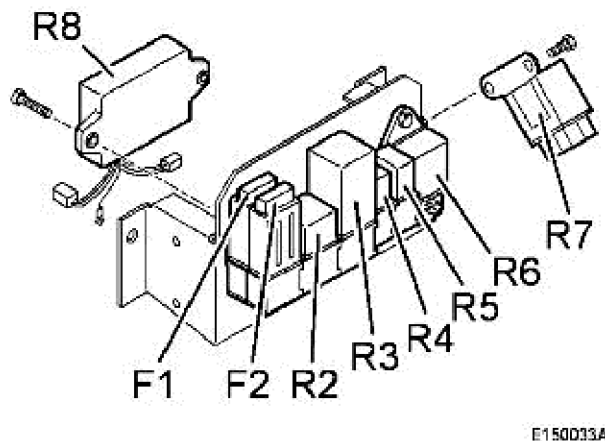

Figure 3

Relays and fuses.

- F1- 40 A-fuse: Main fuse.
- F2- 50 A-fuse: Pre-heating relay.
- R2- Control relay, offsetting / slewing gear.
- R3- Starter relay, engine.
- R4- Control relay, lighting.
- R5- Relay, engine fuses.
- R6- Delay relay. Engine pre-heating.
- R7- Relay, pre-heating of engine.
- R8- Control box, engine fuses.

When the starting safety relay is operated:

- Fuse holder → Starting safety relay → This way the current flows to connection S on the starter. The starter cranks the engine. The engine starts.

Start interlock**If the ignition switch remains permanently in START position:**

- Current from connection (N, PINZ) on the generator → flows to pin 3 of the starter safety relay, which is switched off. For this reason the starter will stop.
- While the engine is running the starter cannot engage, even when the ignition switch is turned to START position.

Stop

- When the ignition switch is released, it will automatically return to position ON. When the ignition switch is turned to position OFF the current flow from the ACC terminal on the ignition switch to the shut-down motor is interrupted. No electric current flows to the shut-down motor, the engine will stop.

VOLVO

Construction Equipment

PROSIS Service Information

Document Title : Testing method	Function Group : 330	Information Type : Service Information	Print Date : 19/10/2011
Profile : CEX, EC15B XTV (Volvo) [GB]			

Testing method



Figure 1
Ignition switch, testing method

- Continuity test in every position with tester.

Pre-heating/starting

NOTE

The engine can only be started when the left hand arm rest ([See figure](#)) is folded up and the safety switch - SW9 ([See figure](#)) is therefore not actuated.
Relay - RE1 is ON via - SW9.

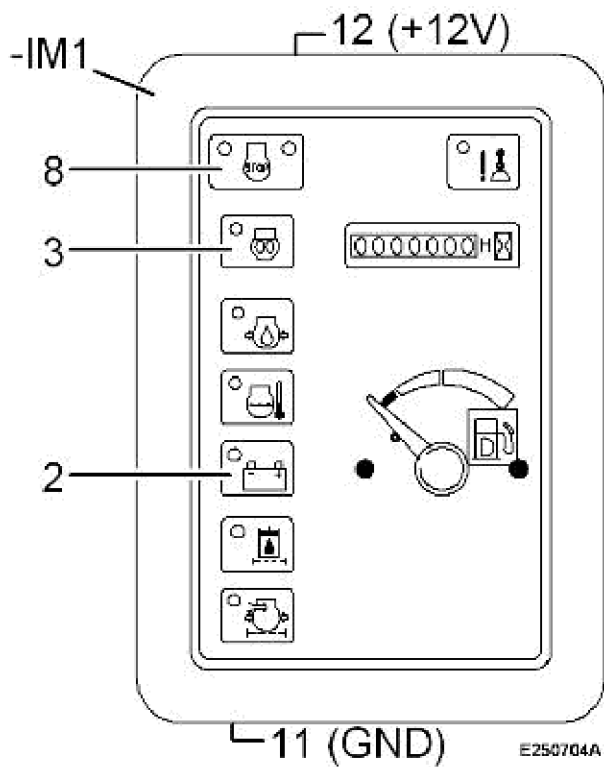

Figure 2

- IM1Dashboard

Connection assignment for dashboard (- IM1)

- 2 Battery charge condition gauge
- 3 Preheating
- 8 Engine OFF

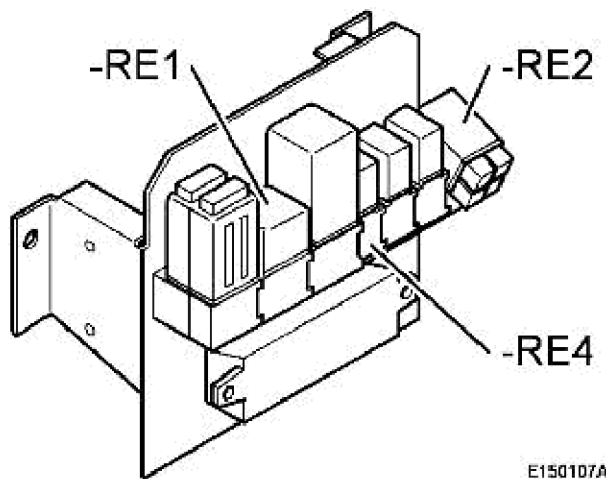

Figure 3

- RE1 Starter relay
- RE2 Relay for pre-heating element
- RE4 Relay for engine safety
- RE7 Relay for pre-heating time

Relay group

Locked console left, console right
(starting, working hydraulics, secondary hydraulics)

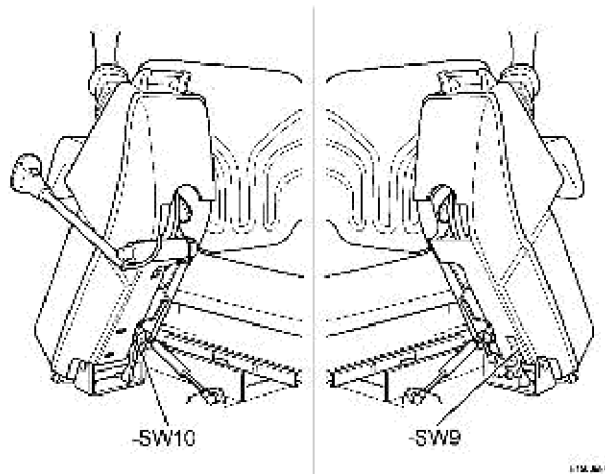

Figure 4

- SW9 Safety switch for working hydraulics (console, left)
- SW10 Safety switch, secondary hydraulics (console, right)

Folding down the consoles operates the safety switches - SW9 and - SW10 .

The control circuit for starter - MO1 is released via relay - RE1 . The starter can now be operated via ignition switch - SW1 ([See figure](#)).

NOTE The control circuit for the starter - MO1 is released if at least one console is folded down.

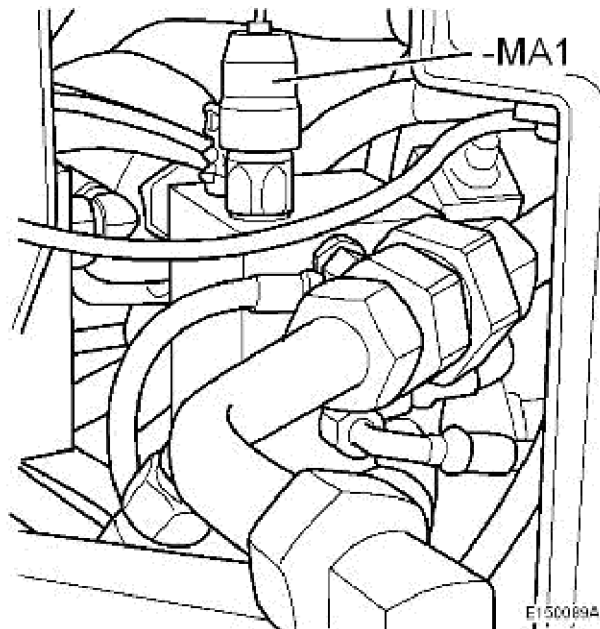

Figure 5

- MA1 Safety solenoid valve, working hydraulics

The working hydraulics is enabled via safety solenoid valve - MA1 .

The solenoid valve - MA1 is located in the driver's cab under the floor plate on the left hand side.

Starting system

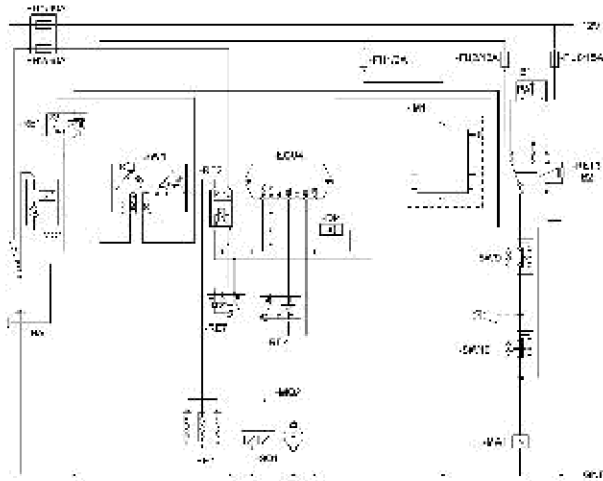
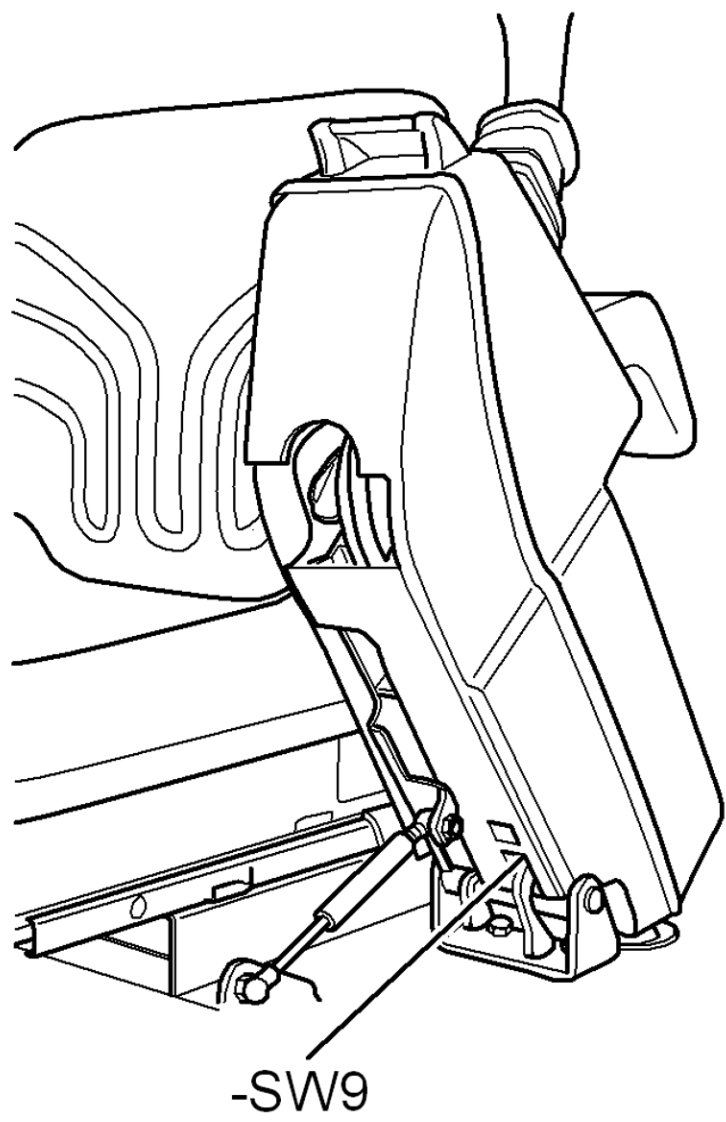
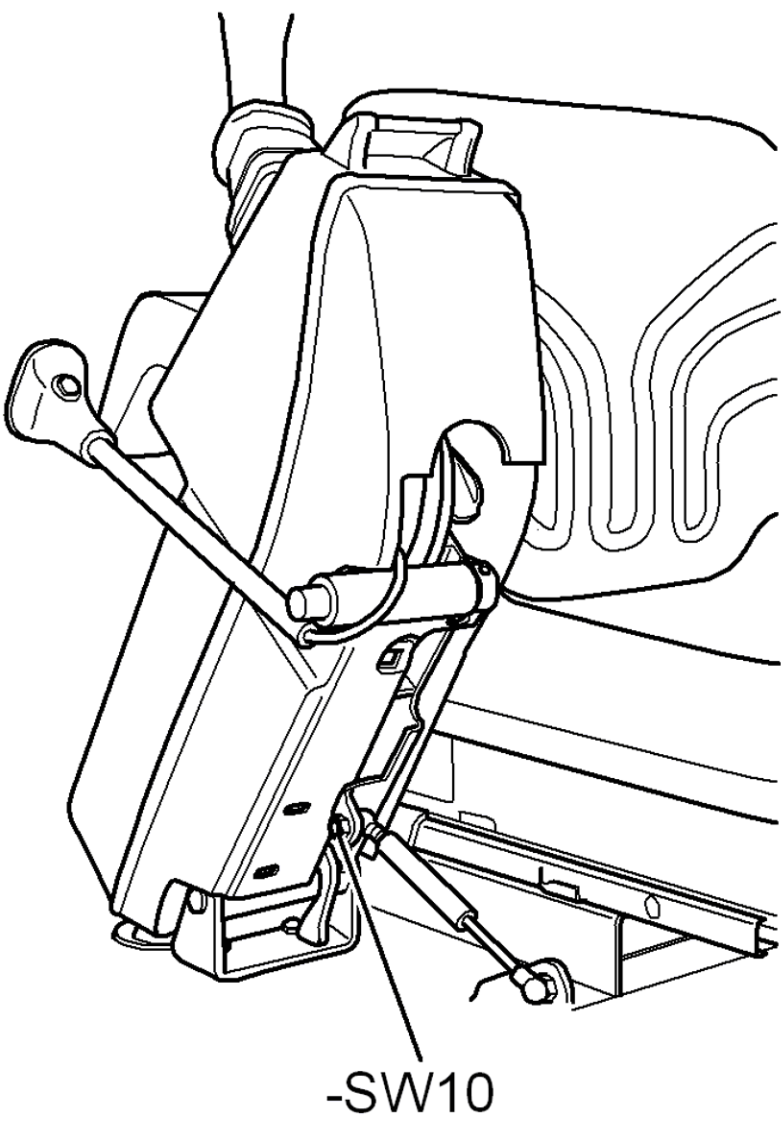
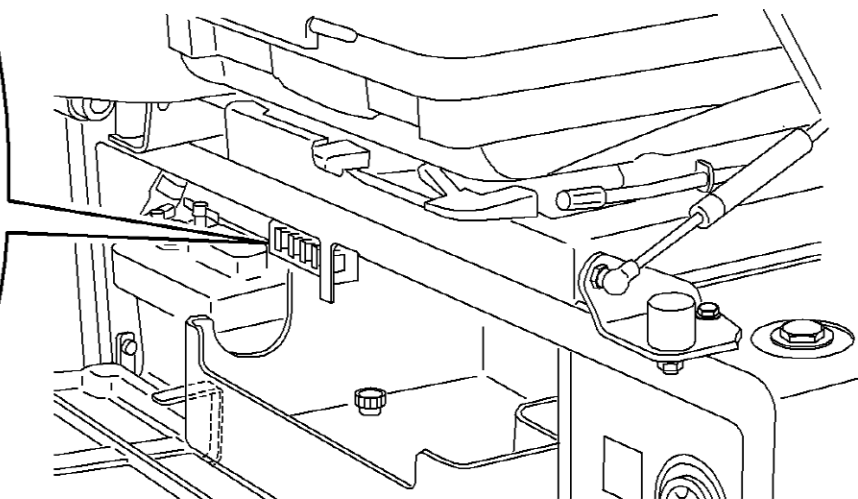

Figure 8

- 1 Switch - SW10 bridged.



6	F	5	E	4	D	3	C	2	B	1	A
FU6								FU2		FU1	





Construction Equipment

PROSIS Service Information

Document Title : Ignition switch	Function Group : 3318	Information Type : Service Information	Print Date : 19/10/2011
Profile : CEX, EC15B XTV (Volvo) [GB]			

Ignition switch

- The switch distributes the current supply exactly targeted to the different electrical components of the engine starting and shut down system, the pre-heating circuit and the accessory circuits.

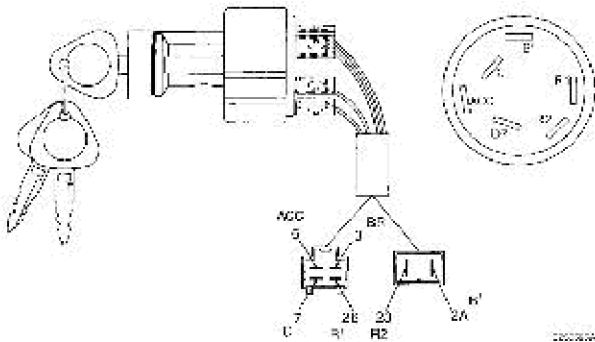
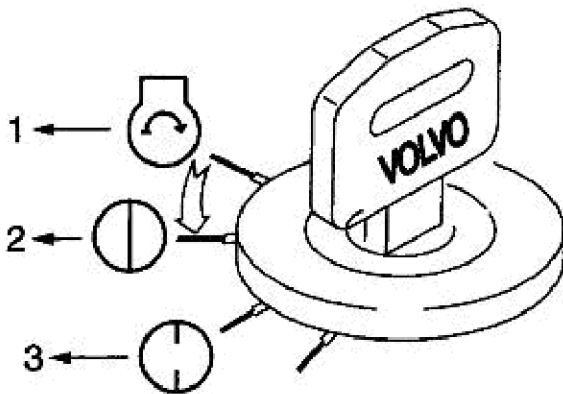

Figure 1
Ignition switch

Switch circuit



E25052/A

Figure 2
Ignition switch, terminals

1. START
2. ON / PRE
3. OFF

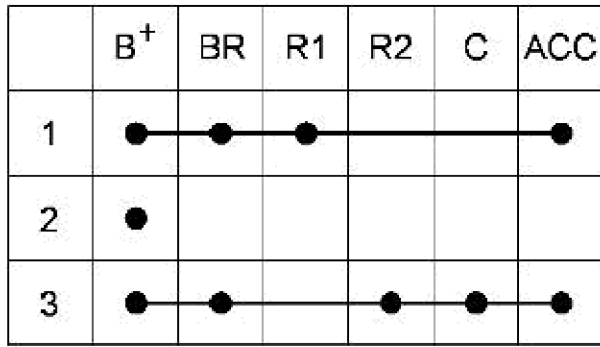

E250523A

Figure 3
Terminals:

1. Run (ON), pre-heating (PRE)
2. Shut down (OFF)
3. Start (START)

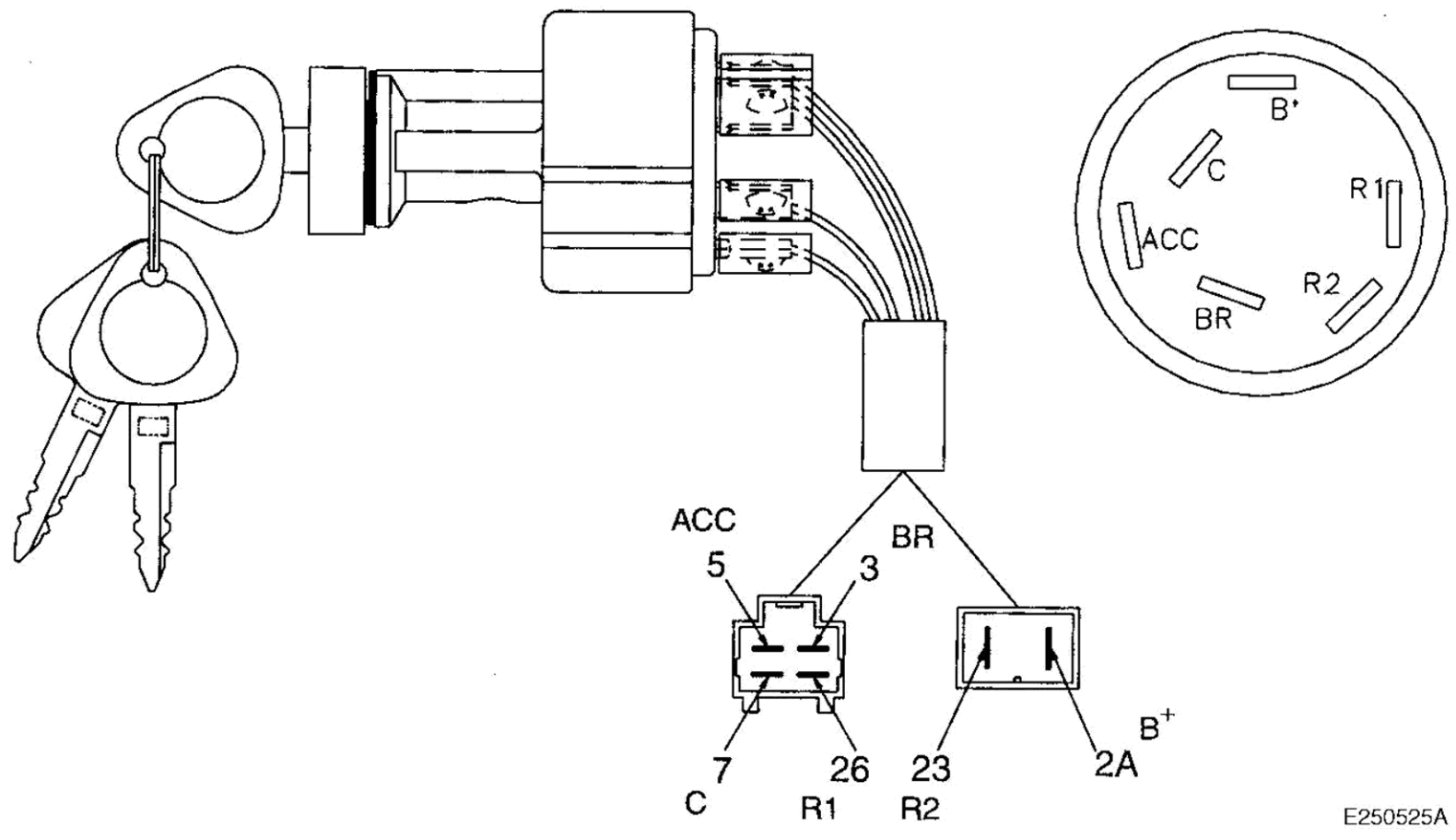



Construction Equipment

PROSIS Service Information

Document Title : Ignition switch, specification	Function Group : 3318	Information Type : Service Information	Print Date : 19/10/2011
Profile : CEX, EC15B XTV (Volvo) [GB]			

Ignition switch, specification

Ignition switch, specification

Item	Specification
Max. current	B-BR, B-ACC: 30 A B-R1, B-R2: 60 A B-C: Hort term 75 A, continuous 22 A
Insulating resistance	1 MΩ or more (500 V mega-ohmmeter)

Ignition switch, line specification

No.	Line specification
2A	B ⁺ , AVS 5,0 Y
3	BR, AVS 3.0 R/W
5	ACC, AVS 3.0 R
23	R2, AVS 5.0 W
7	C, AVS 3.0 R/SB
26	R1, AVS 3.0 R/GN



Construction Equipment

PROSIS Service Information

Document Title : Key-operated engine shut down system with EDD-solenoid	Function Group : 3318	Information Type : Service Information	Print Date : 19/10/2011
Profile : CEX, EC15B XTV (Volvo) [GB]			

Key-operated engine shut down system with EDD-solenoid

General

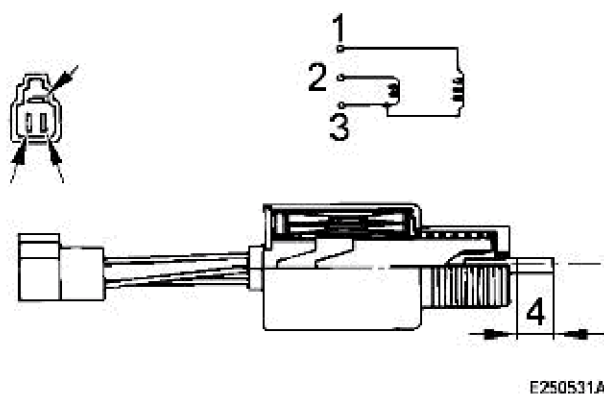

Figure 1
Key operated shut down system

1. Red
2. White
3. Blue
4. Stroke 13 ± 0.5 mm

The engine shut down system controlled by an EDD-solenoid (start excitation) is based on the follow principle:

When the ignition switch is turned to position S the feed coil of the solenoid is excited, whereby the pressure pin is pulled in. While the ignition switch is in position ON and the system is in operation, the holding coil of the solenoid is still excited, so that the pressure pin remains retracted.

If the current flow to the solenoid is interrupted because of a defective cable or any other reason, the solenoid is no longer excited so that the pressure bin is extended by the pressure force, thereby holding the rack of the injection pump in a position where no fuel injection takes place. The engine is shut down.

Similar to the engine shut-down system with EDA-solenoid (shut-down excitation) this system is also a safety device which brings the injection system to a state where no injection takes place if a cable is interrupted or the ignition switch is turned back to OFF.

The cables of the solenoid are colour coded:

Cables with colour coding

N°	Colour of cable	Connected to
1	Red	FEED (feed coil)/starter
2	White	HOLD (holding coil)/ignition switch
3	Blue	COM (ground)

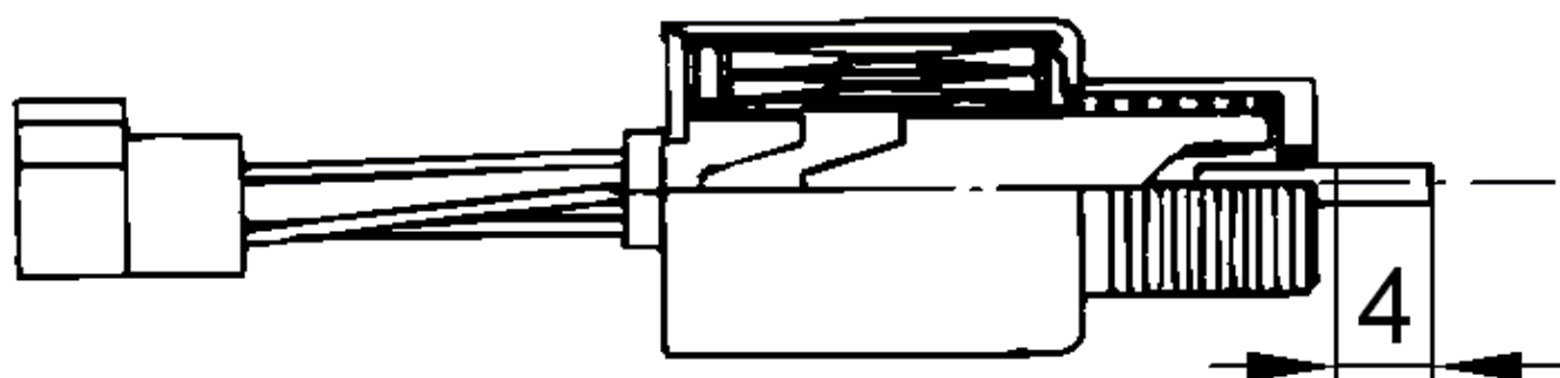
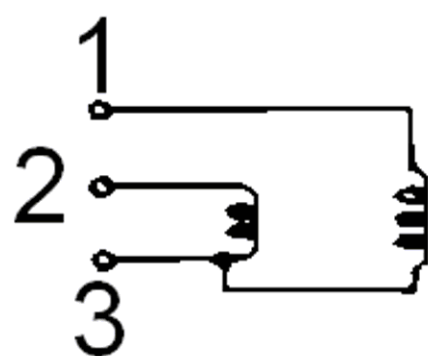

E250531A



Construction Equipment

PROSIS Service Information

Document Title : Installation of the solenoid	Function Group : 3318	Information Type : Service Information	Print Date : 19/10/2011
Profile : CEX, EC15B XTV (Volvo) [GB]			

Installation of the solenoid

Op nbr 27301

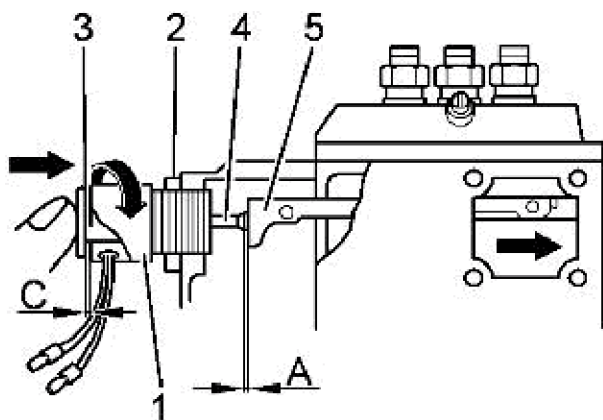

Figure 1
Connection of the solenoid

- 1. Solenoid
- 2. Nut
- 3. Rack play 0.15...0.20 mm
- 4. Rack

Solenoid, specification

Designation	YMS-1
Type	Solenoid
Coil resistance	1,6 ± 10% at 20 °C
Stroke, mm	10 ± 0,5
Operating voltage, V	9 V - 15 DC

- Remove the cover from the connecting rod.
- Screw nut (2) onto solenoid (1), then tighten the nut down to the inner end of the thread of the solenoid.
- Cover the thread of the solenoid with sealing paste.

NOTE The sealing paste must be applied to those parts of the thread, which are covered when the solenoid is mounted to the engine block.

- Turn solenoid (1) into the governor housing.

- While moving the rack to both directions, tighten the solenoid (1) until the rack touches the pressure pin of the solenoid and is no longer moveable.
- Turn the electro-magnet (1) for approx. 30 to 45 degrees in opposite direction (the play between rack and shaft must be 0.15...0.20 mm).
- Tighten nut (2) with the specified torque of 49 Nm.
- Fasten the cover of the connecting rod to the injection pump.
- Start the engine. Turn the ignition switch to OFF. The pressure pin must now be extracted and the rack pushed back, so that the engine is shut down.

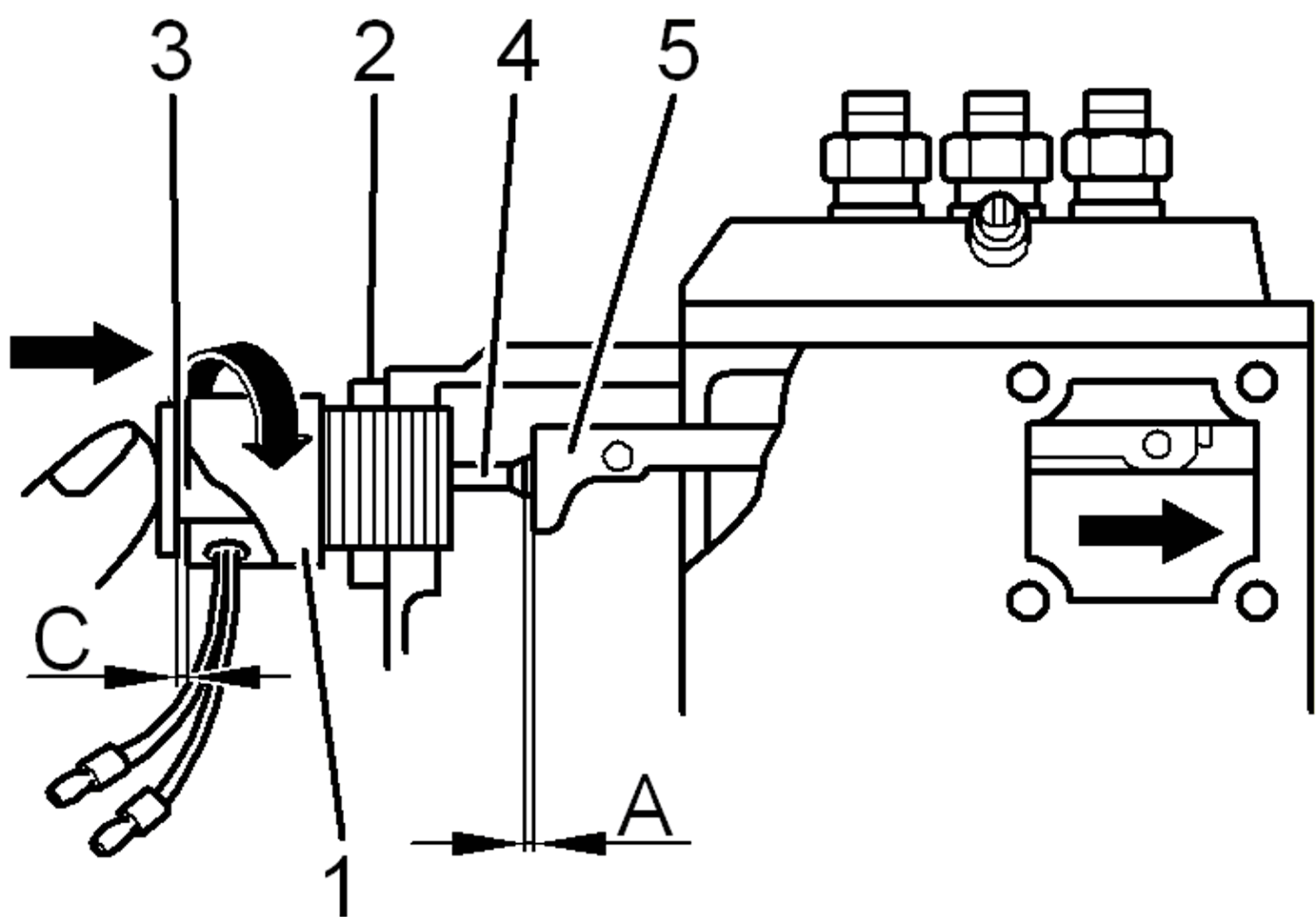

E250752A



Construction Equipment

PROSIS Service Information

Document Title : Characteristics of the glow plug system	Function Group : 333	Information Type : Service Information	Print Date : 19/10/2011
Profile : CEX, EC15B XTV (Volvo) [GB]			

Characteristics of the glow plug system

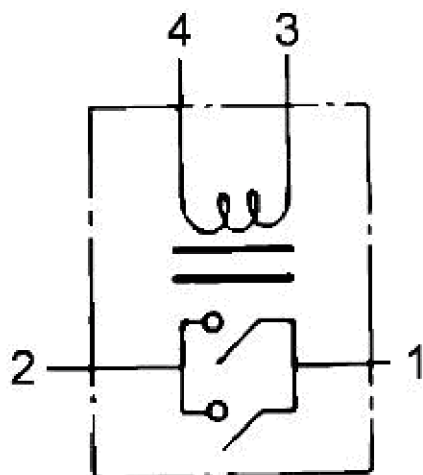
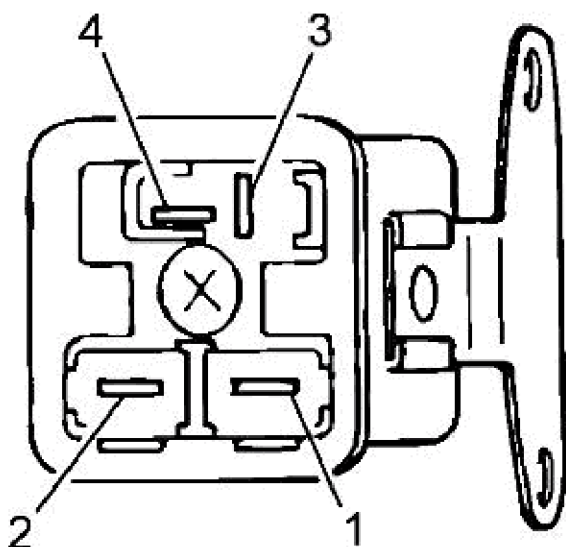

E250235A

Figure 1
Glow plug relay

Pre-heating plug relay

Designation	G71SP
Rated voltage	12 V DC
Continuous rated power	1 minute
Coil resistance	13

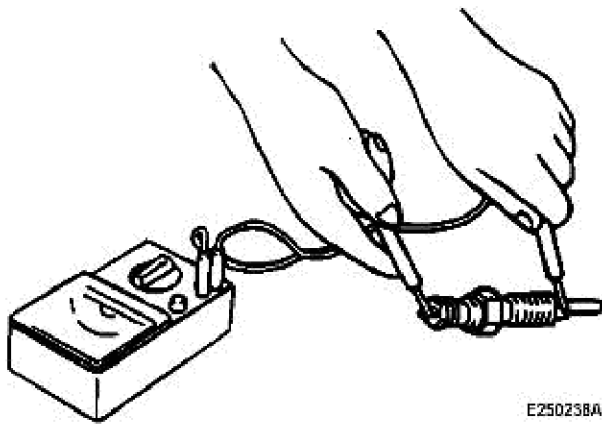

E25025BA

Figure 2
Checking the glow plug



Construction Equipment

PROSIS Service Information

Document Title : Checking the glow plug	Function Group : 333	Information Type : Service Information	Print Date : 19/10/2011
Profile : CEX, EC15B XTV (Volvo) [GB]			

Checking the glow plug

Voltage regulation, specification

Op nbr

[Ohmmeter](#)

Glow plugs, specification

Designation	Y-145T
Regulator, type	with sheath
Rated voltage, V	10,5
Current drain A	9,7 ± 1.0 (30 seconds at rated voltage)
Resistance, Ω	0,55

Check the current flow between terminal and housing, as shown in the illustration. If the current flow is not assured or the resistance is too high, replace the glow plug



Construction Equipment

PROSIS Service Information

Document Title : Checking the glow plug	Function Group : 333	Information Type : Service Information	Print Date : 19/10/2011
Profile : CEX, EC15B XTV (Volvo) [GB]			

Checking the glow plug

Voltage regulation, specification

Op nbr

[Ohmmeter](#)

Glow plugs, specification

Designation	Y-145T
Regulator, type	with sheath
Rated voltage, V	10,5
Current drain A	9,7 ± 1.0 (30 seconds at rated voltage)
Resistance, Ω	0,55

Check the current flow between terminal and housing, as shown in the illustration. If the current flow is not assured or the resistance is too high, replace the glow plug

VOLVO

Construction Equipment

PROSIS Service Information

Document Title : Installing the glow plug	Function Group : 333	Information Type : Service Information	Print Date : 19/10/2011
Profile : CEX, EC15B XTV (Volvo) [GB]			

Installing the glow plug

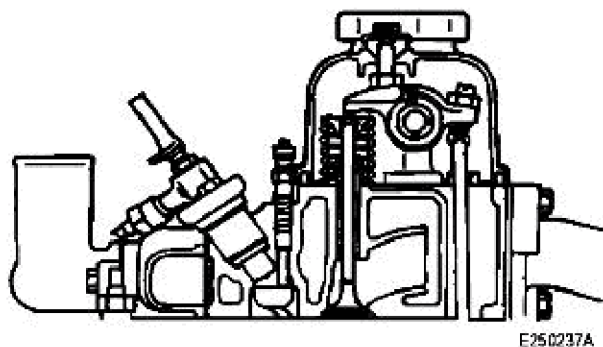

Figure 1
Glow plug installation

Installation

Op nbr 379



- Screw the pre-heating plug into the cylinder head and tighten with 17.2 ± 2.5 Nm.
- Connect the electrical supply and tighten the nut with $0.98 \dots 1.47$ Nm.



Construction Equipment

PROSIS Service Information

Document Title : Boom/cabin/weather roof	Function Group : 350	Information Type : Service Information	Print Date : 19/10/2011
Profile : CEX, EC15B XTV (Volvo) [GB]			

Boom/cabin/weather roof

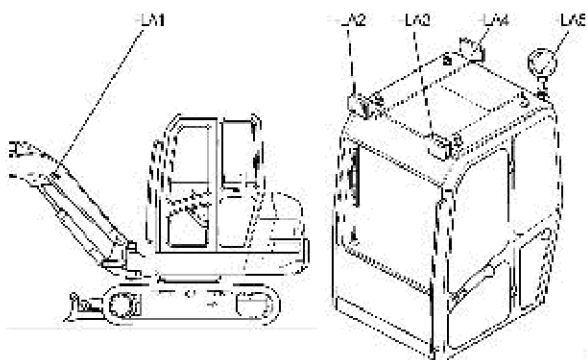

Figure 1

- LA1 Headlights, boom
- LA2 Headlight, cabin front right
- LA3 Headlight, cabin/weather roof, front left
- LA4 Headlight, cabin/weather roof, rear
- LA5 Flashing beacon

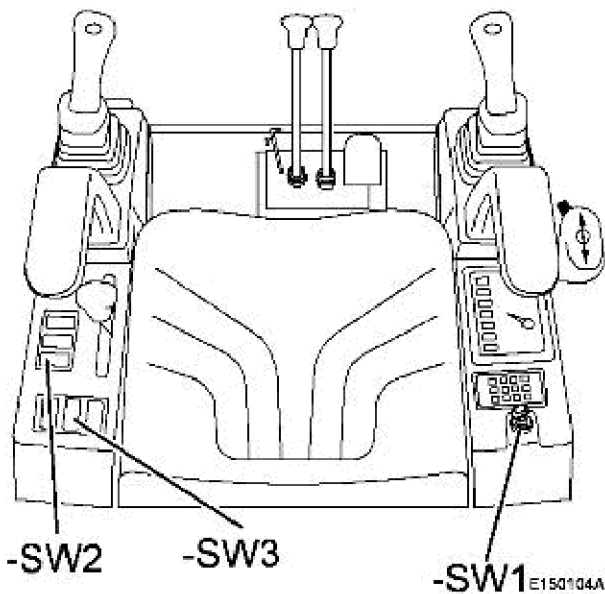
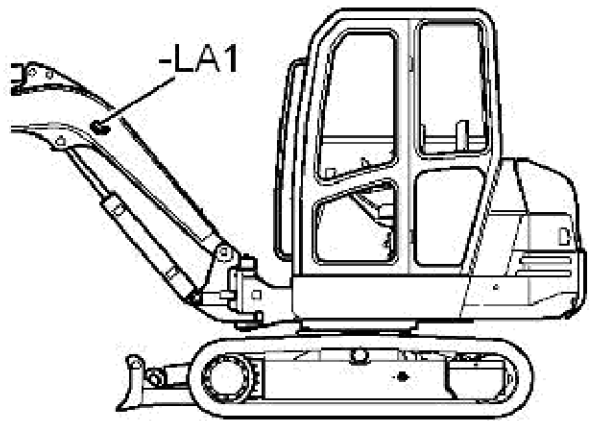

Figure 2

- SW1 Ignition switch
- SW2 Headlights, boom
- SW3 Headlight, cabin/weather roof

Headlights, boom/cabin/weather roof



E250733A

Figure 3

- LA1 Headlights, boom

Headlights, boom

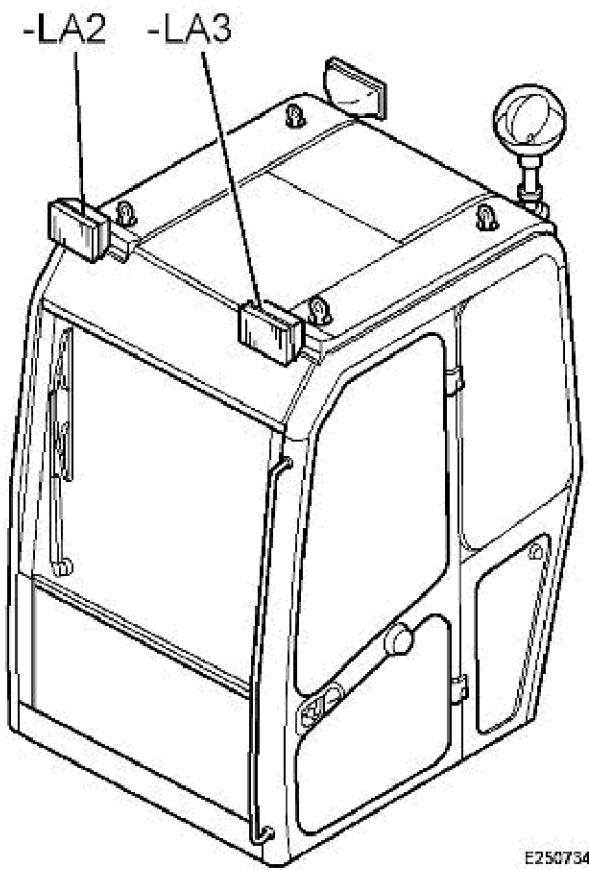

E250734A

Figure 4

- LA2 Headlight, cabin front right
- LA3 Headlights, weather roof front left

Headlight, cabin/weather roof

Fuses

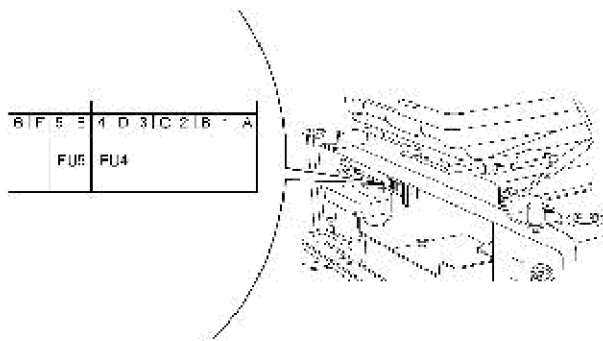

Figure 5

- FU4/20 A Lighting
- FU5/15 A Cabin, alarm system, travel system

Lighting

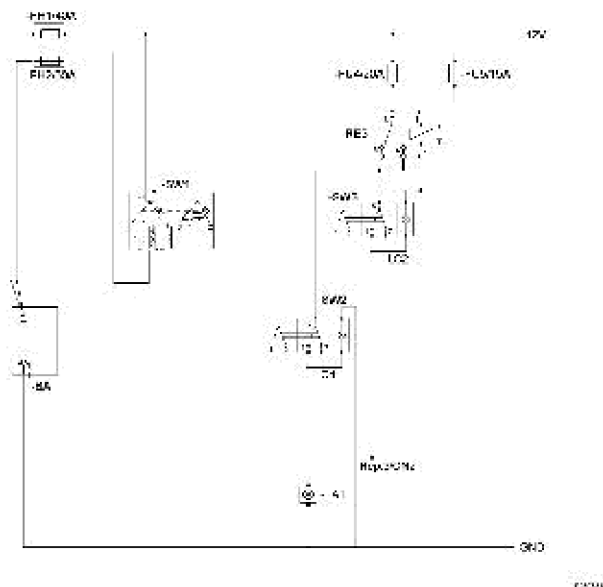
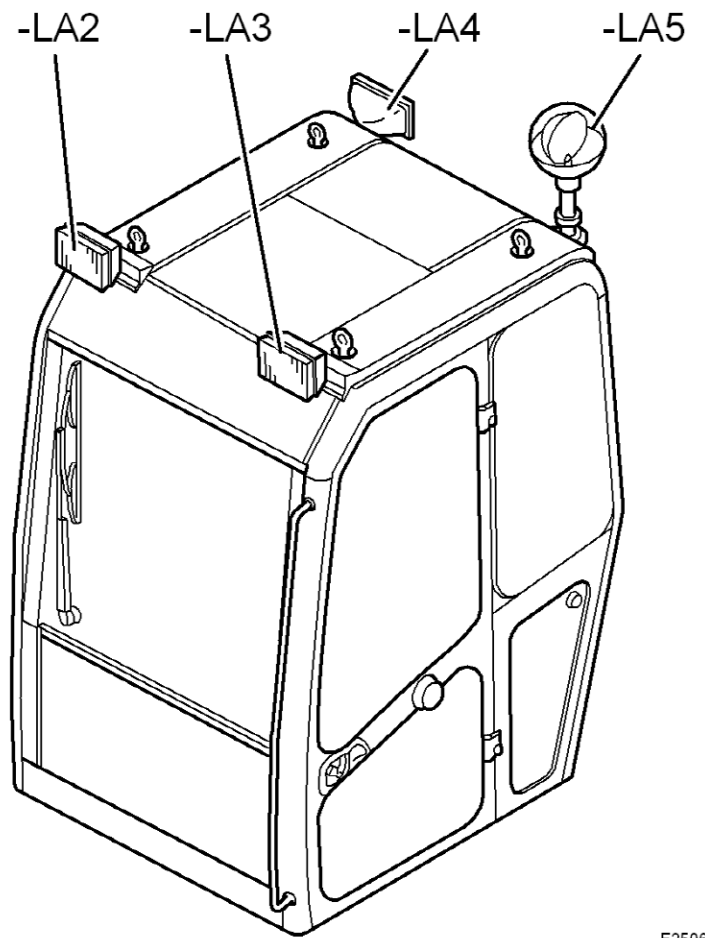
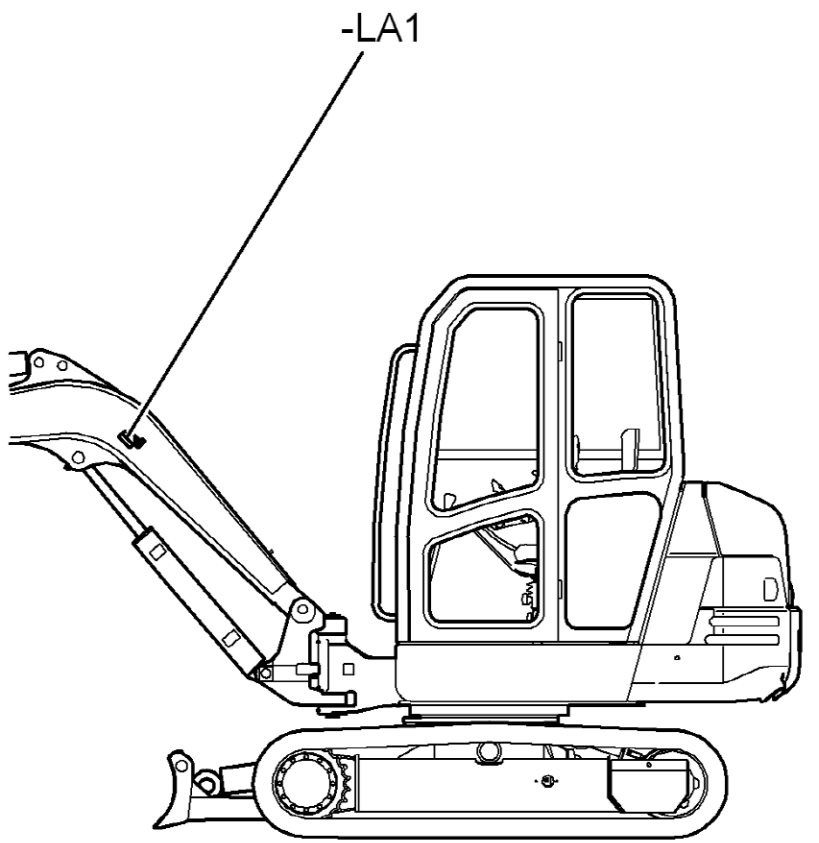
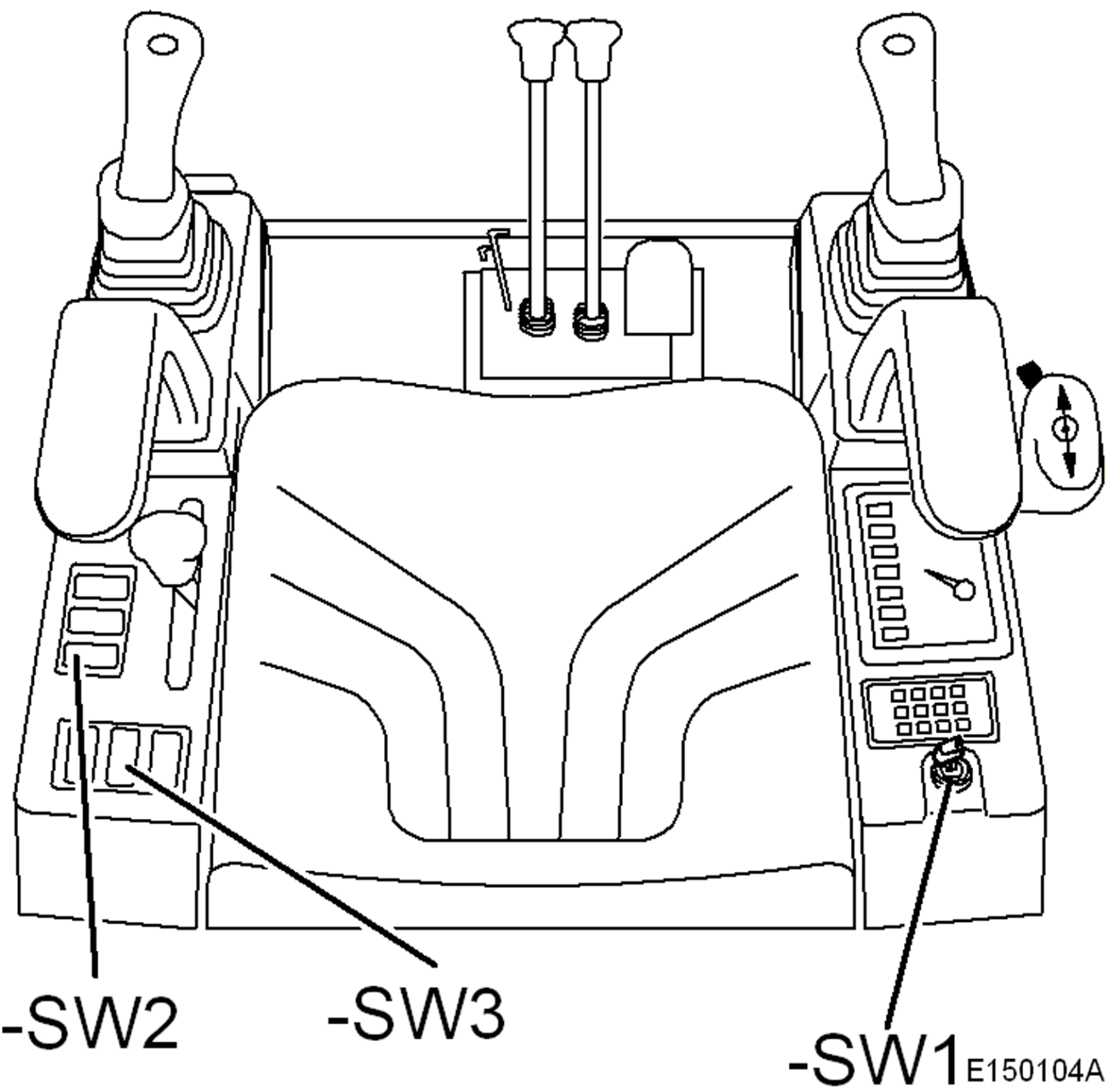

Figure 6





-SW2

-SW3

-SW1 E150104A

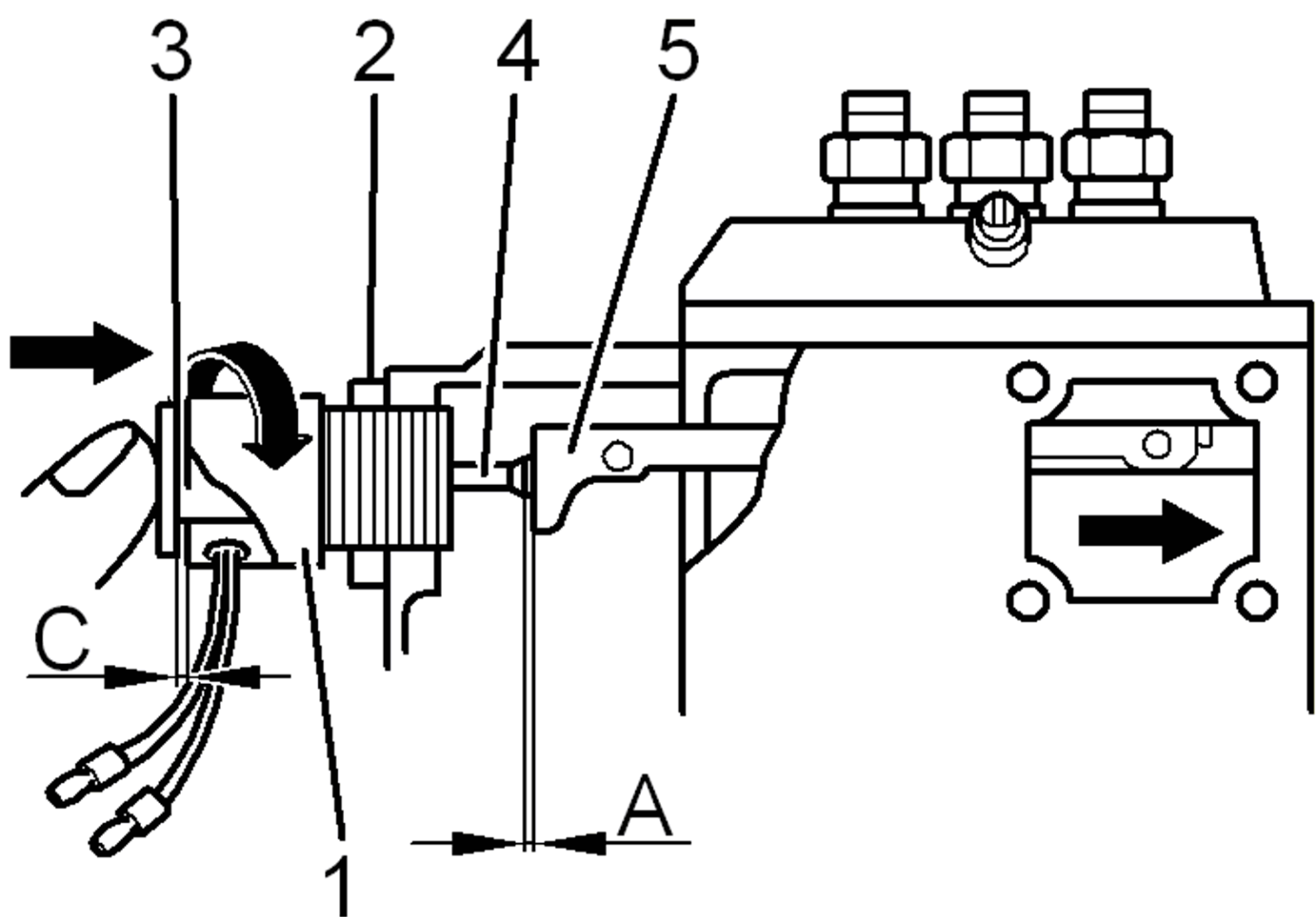

E250752A

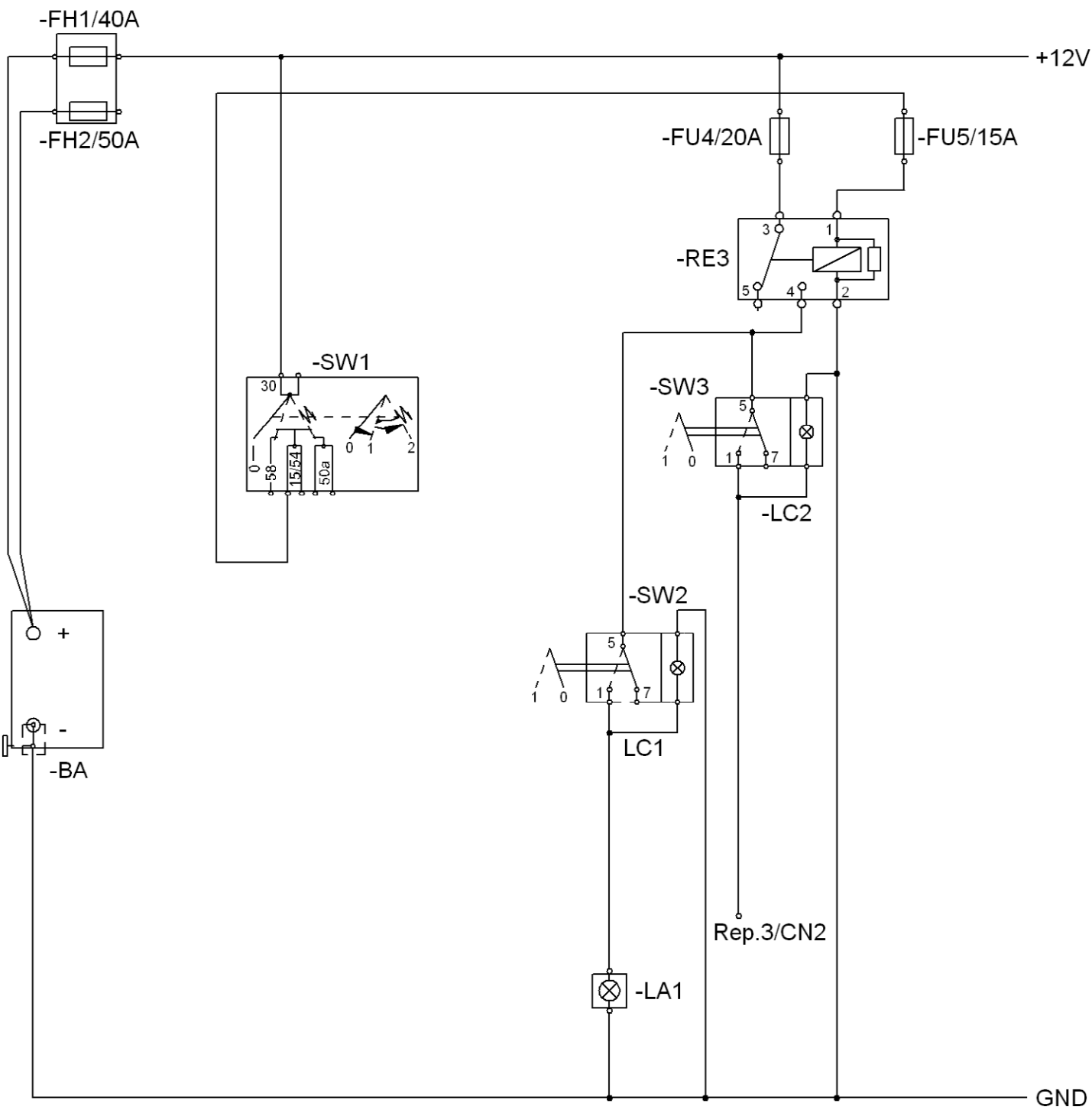



Construction Equipment

PROSIS Service Information

Document Title : Working headlights and main headlights, description	Function Group : 356	Information Type : Service Information	Print Date : 19/10/2011
Profile : CEX, EC15B XTV (Volvo) [GB]			

Working headlights and main headlights, description

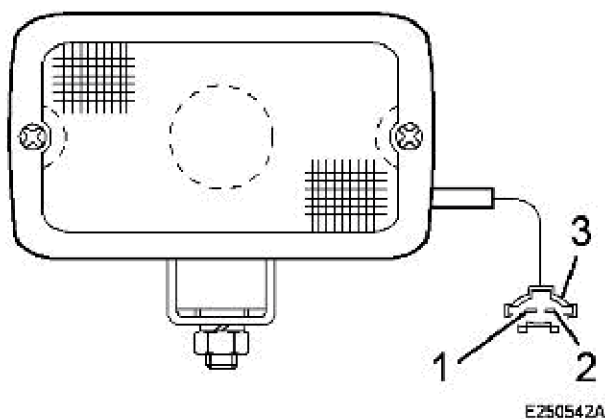

Figure 1
Working headlights and main headlights

1 AVS 1.25 R/W (B⁺)
2 AVS 1.25 SB (E)

3 AVS 1.25 R/BL (B⁺)
4 AVS 1.25 SB (E)



Construction Equipment

PROSIS Service Information

Document Title : Working headlights and main headlights, specification	Function Group : 356	Information Type : Service Information	Print Date : 19/10/2011
Profile : CEX, EC15B XTV (Volvo) [GB]			

Working headlights and main headlights, specification

Item	Specification
Rated voltage	12 V
Electrical power consumption	55 W/light bulb
Light bulb type	Halogen (H3)



Construction Equipment

PROSIS Service Information

Document Title : Operating/control elements on driver's platform	Function Group : 360	Information Type : Service Information	Print Date : 19/10/2011
Profile : CEX, EC15B XTV (Volvo) [GB]			

Operating/control elements on driver's platform

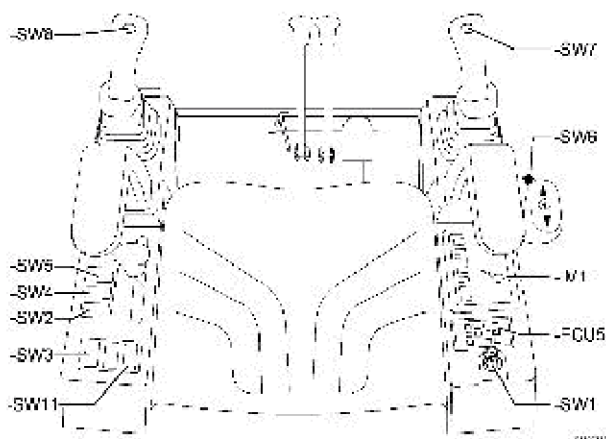
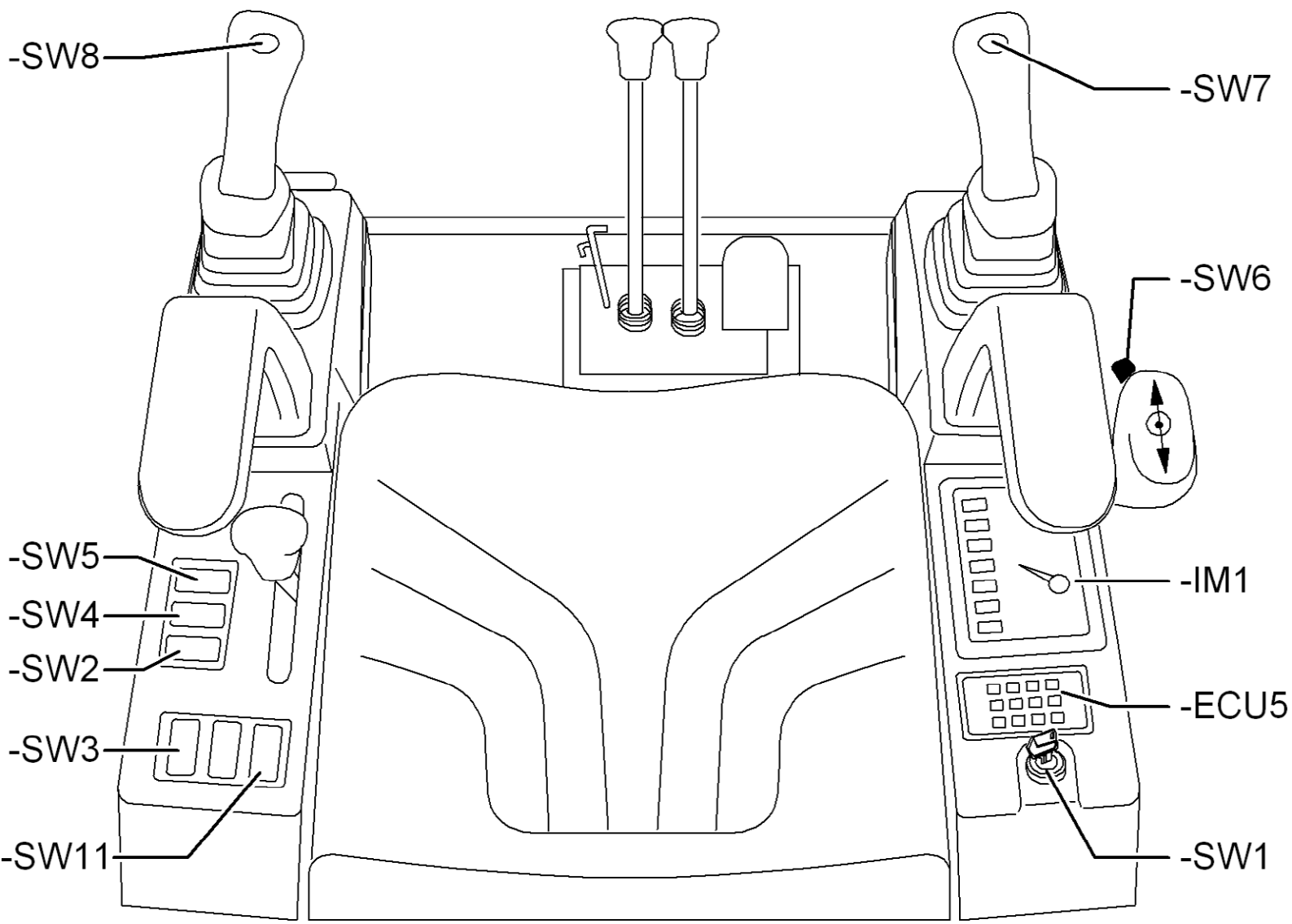

Figure 1

- | | | | |
|--------|--------------------------------------|--------|--|
| - ECU5 | Numerical keyboard for immobilizer | - SW6 | Selector switch, two speed ranges, secondary, variable track |
| - SW1 | Ignition switch | - SW7 | Switch, warning horn |
| - SW2 | Switch for headlights, boom | - SW8 | Switch, slewing/offsetting |
| - SW3 | Switch, headlight cabin weather roof | - SW9 | Safety switch, working hydraulics/starting (console, left) |
| - SW4 | Switch, flashing beacon | - SW11 | Switch, variable track |
| - SW5 | Selector switch, two speed ranges | - IM1 | Dashboard |



VOLVO

Construction Equipment

PROSIS Service Information

Document Title : Driver's cab	Function Group : 360	Information Type : Service Information	Print Date : 19/10/2011
Profile : CEX, EC15B XTV (Volvo) [GB]			

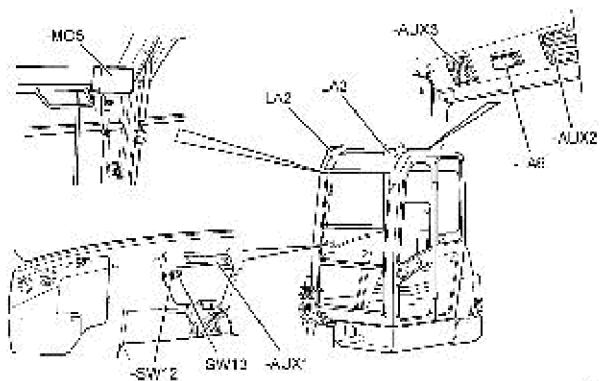
Driver's cab**Figure 1**

- AUX1 Radio
- AUX2 Loudspeaker, left
- AUX3 Loudspeaker, right
- LA2 Headlight, cabin front right
- LA3 Headlight, cabin front left
- LA6 Cabin ceiling light
- MO5 Windscreen wiper motor, front screen
- SW12 Switch for ventilation/cabin heating
- SW13 Switch for windscreen wiper, front screen

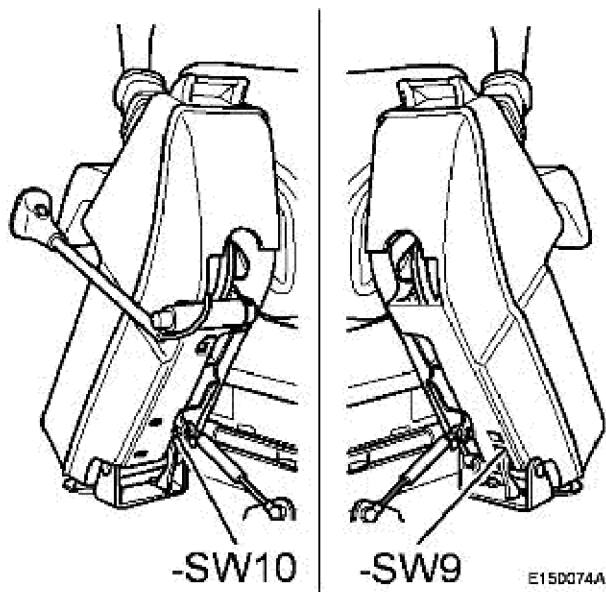
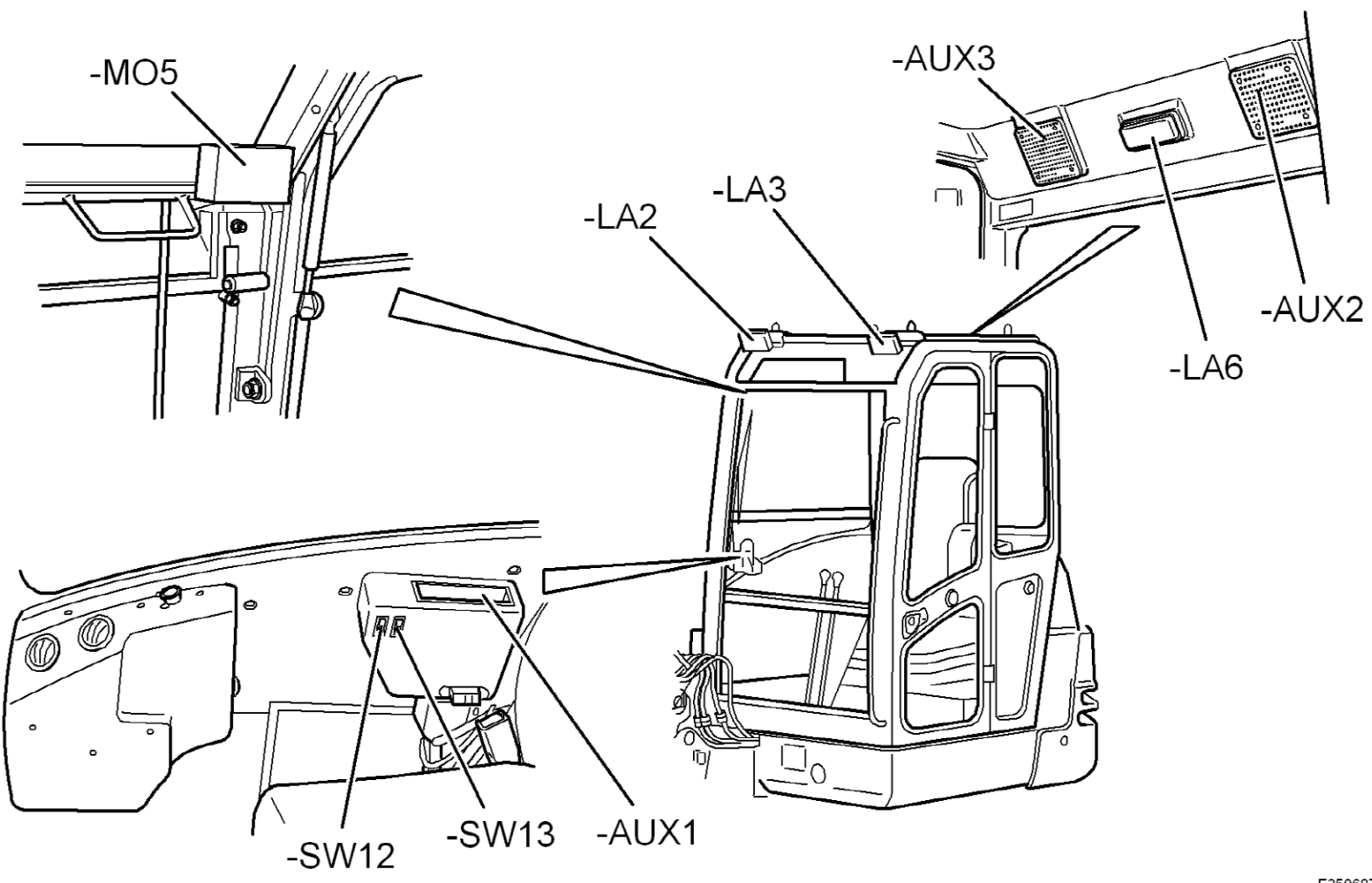

Figure 2

- - SW9 Safety switch, working hydraulics/starting (console, left)
- - SW10 Safety switch, secondary hydraulics (console, right)





Construction Equipment

PROSIS Service Information

Document Title : Socket	Function Group : 360	Information Type : Service Information	Print Date : 19/10/2011
Profile : CEX, EC15B XTV (Volvo) [GB]			

Socket

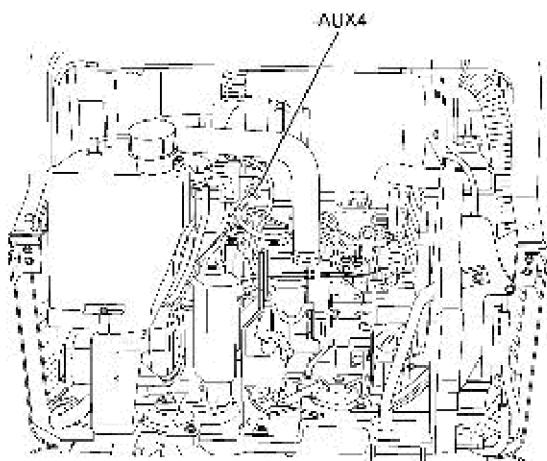

Figure 1

- AUX4 Socket

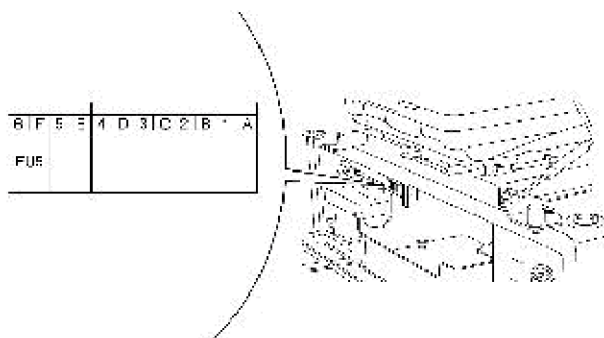

Figure 2

- FU6/15 A Fuse for main signal horn, service plug, car radio memory, flashing beacon, immobilizer

Socket (12 V)

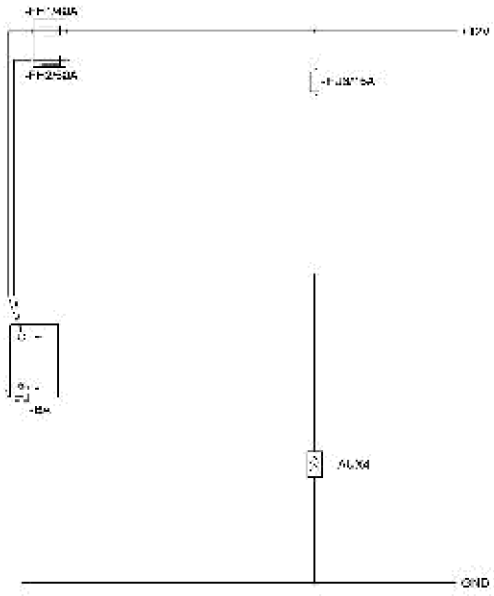
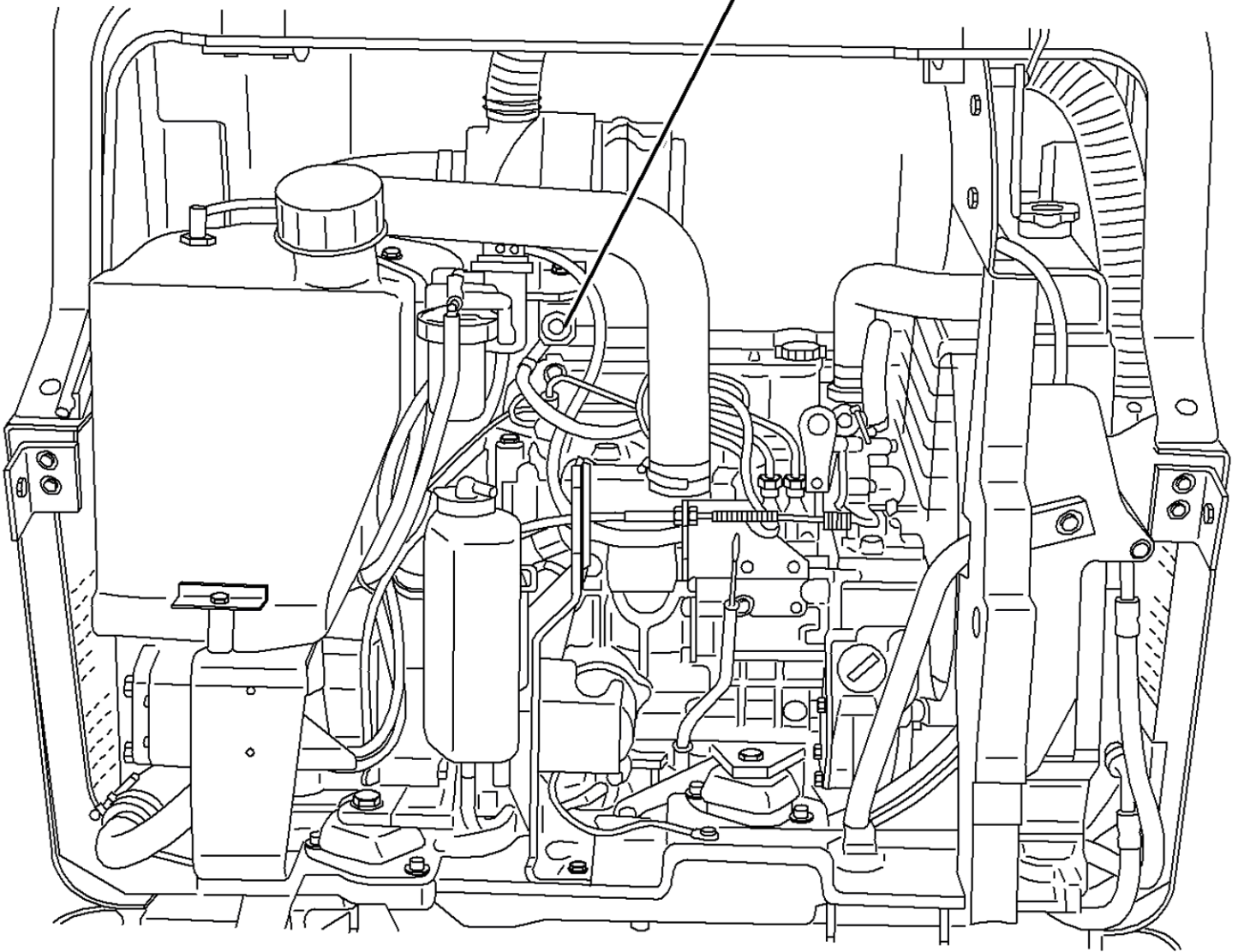
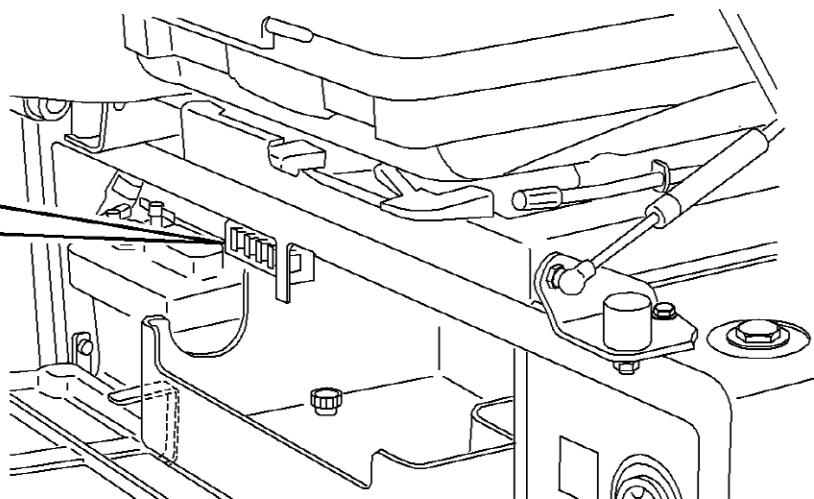

Figure 3

-AUX4



6	F	5	E	4	D	3	C	2	B	1	A
FU6											



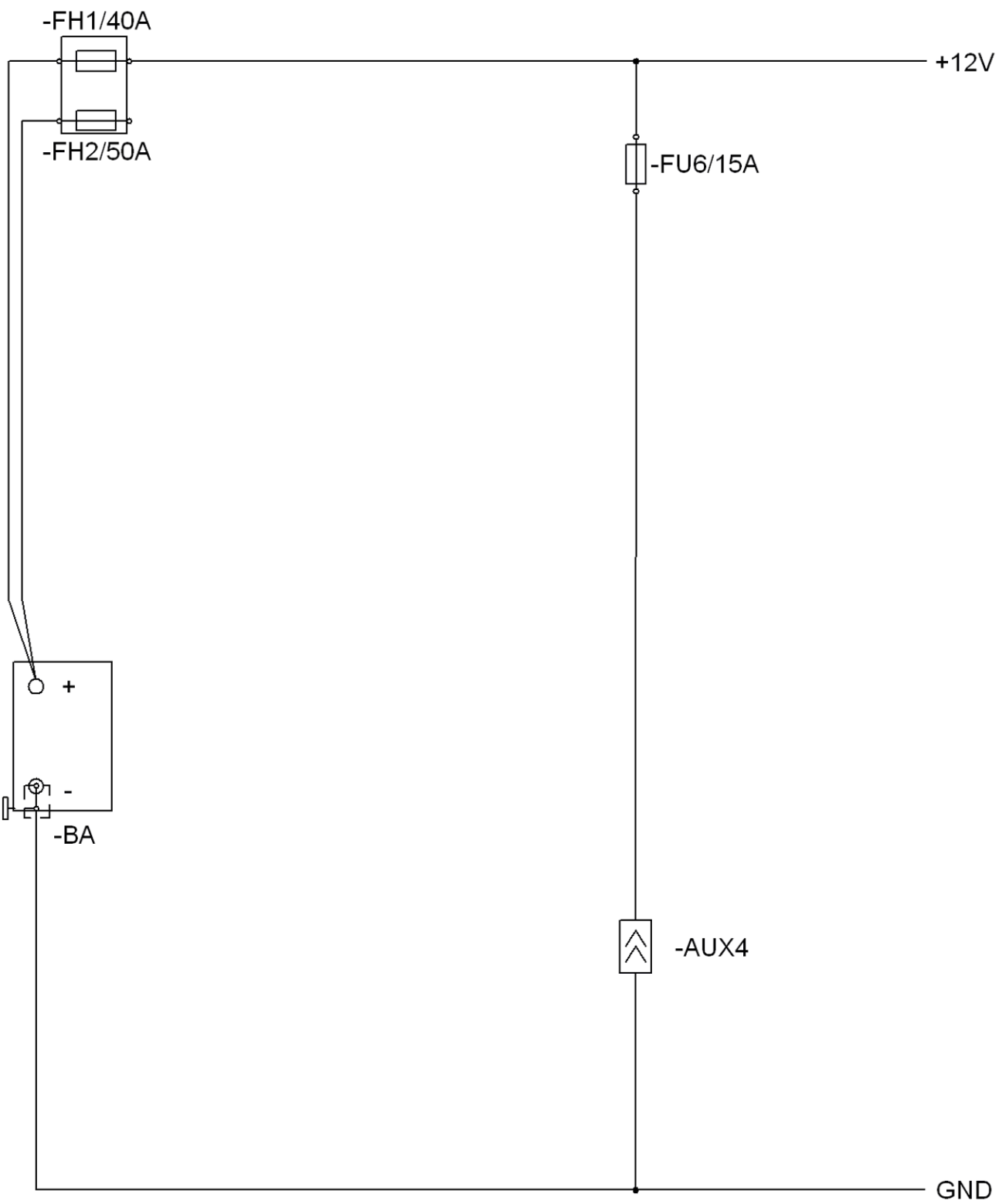

VOLVO

Construction Equipment

PROSIS Service Information

Document Title : Warning system	Function Group : 362	Information Type : Service Information	Print Date : 19/10/2011
Profile : CEX, EC15B XTV (Volvo) [GB]			

Warning system

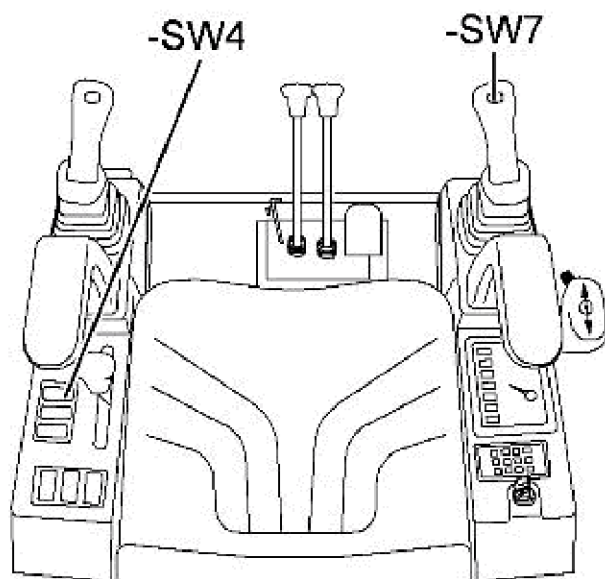

E150099A

Figure 1

- SW4 Switch, flashing beacon
- SW7 Switch, warning horn

Warning horn/flashing beacon

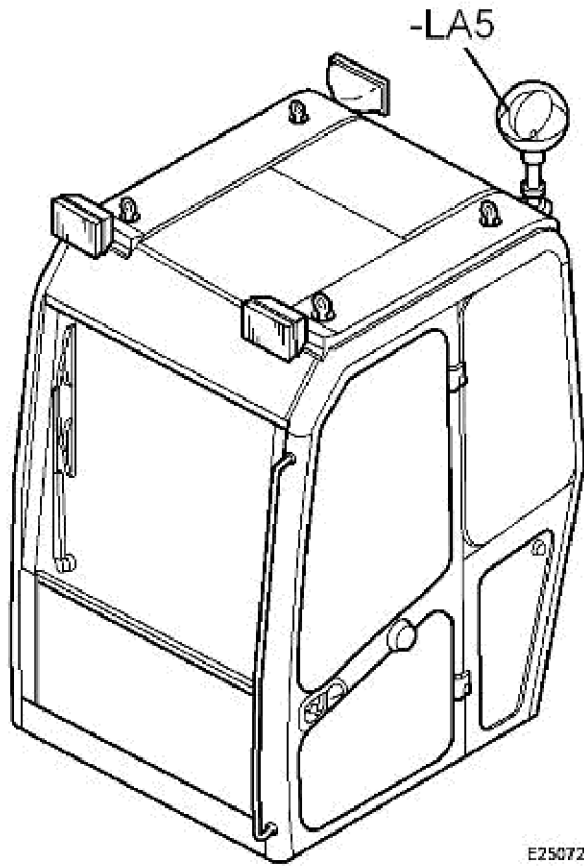

Figure 2

E250723A

- LA5 Flashing beacon

Flashing beacon

Fuses

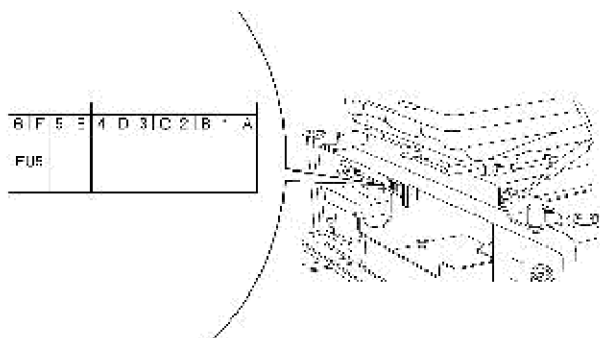

Figure 3

- FU6/15 A Fuse for main warning horn, service plug
Car radio memory, flashing beacon, immobilizer

External warning system

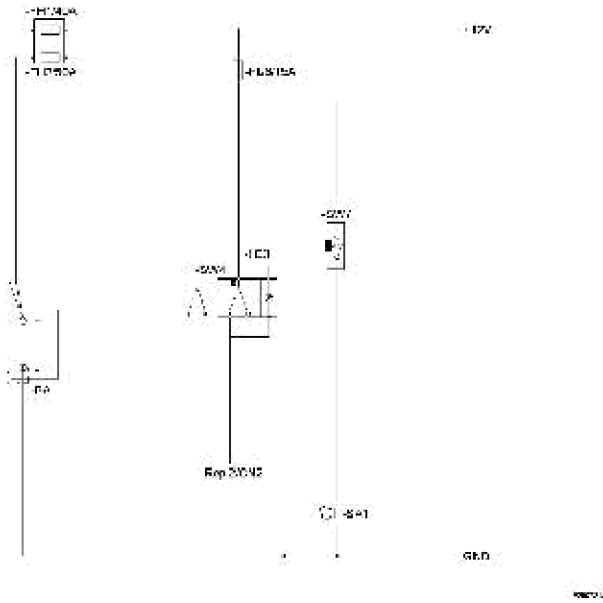
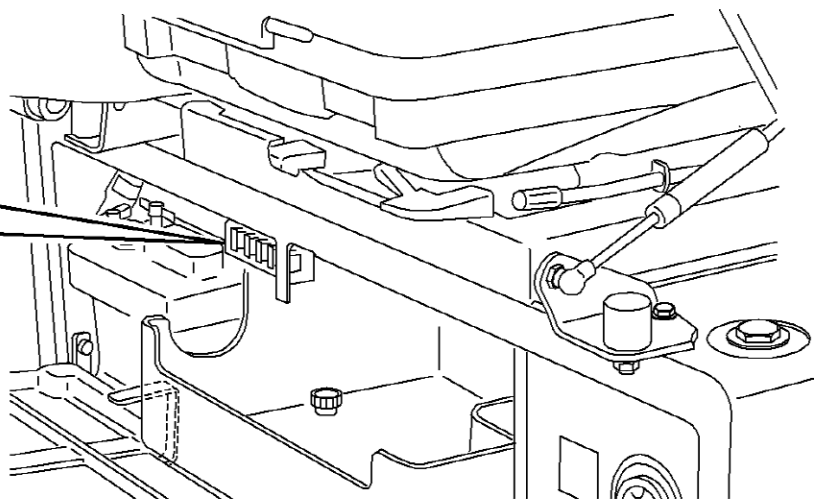
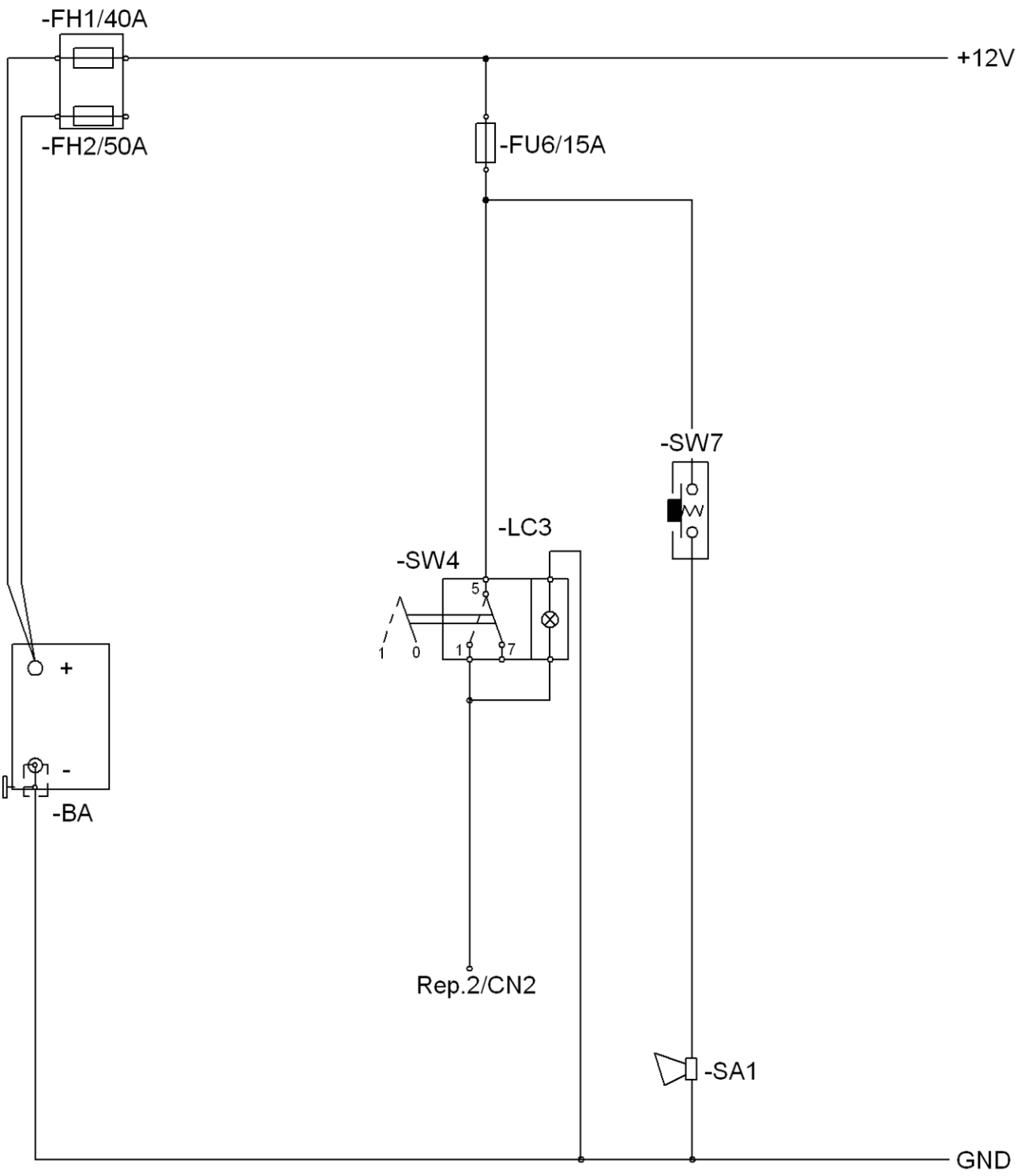

Figure 4

6	F	5	E	4	D	3	C	2	B	1	A
FU6											







Construction Equipment

PROSIS Service Information

Document Title : Main wiring loom/main plug connector cabin	Function Group : 371	Information Type : Service Information	Print Date : 19/10/2011
Profile : CEX, EC15B XTV (Volvo) [GB]			

Main wiring loom/main plug connector cabin

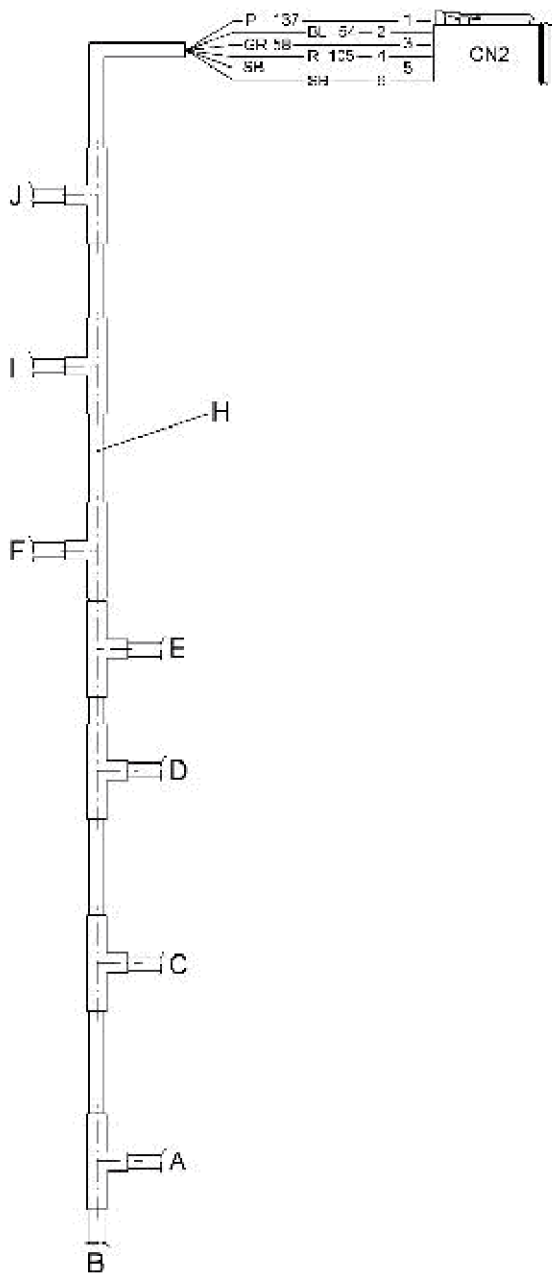

Figure 1

51801163

- A Wiring loom for engine
- B Wiring loom, left hand console
- F Wiring loom for fuse box
- H Main wiring loom

C Connection - **MA1**, - **MA2**, - **B2**
D Wiring loom relay
E Wiring loom for engine

I Wiring loom solenoid valves - **MA3**, - **MA4**,
boom head lights - **LA1**, warning horn - **SA1**
CN2 Main plug connectors, cabin

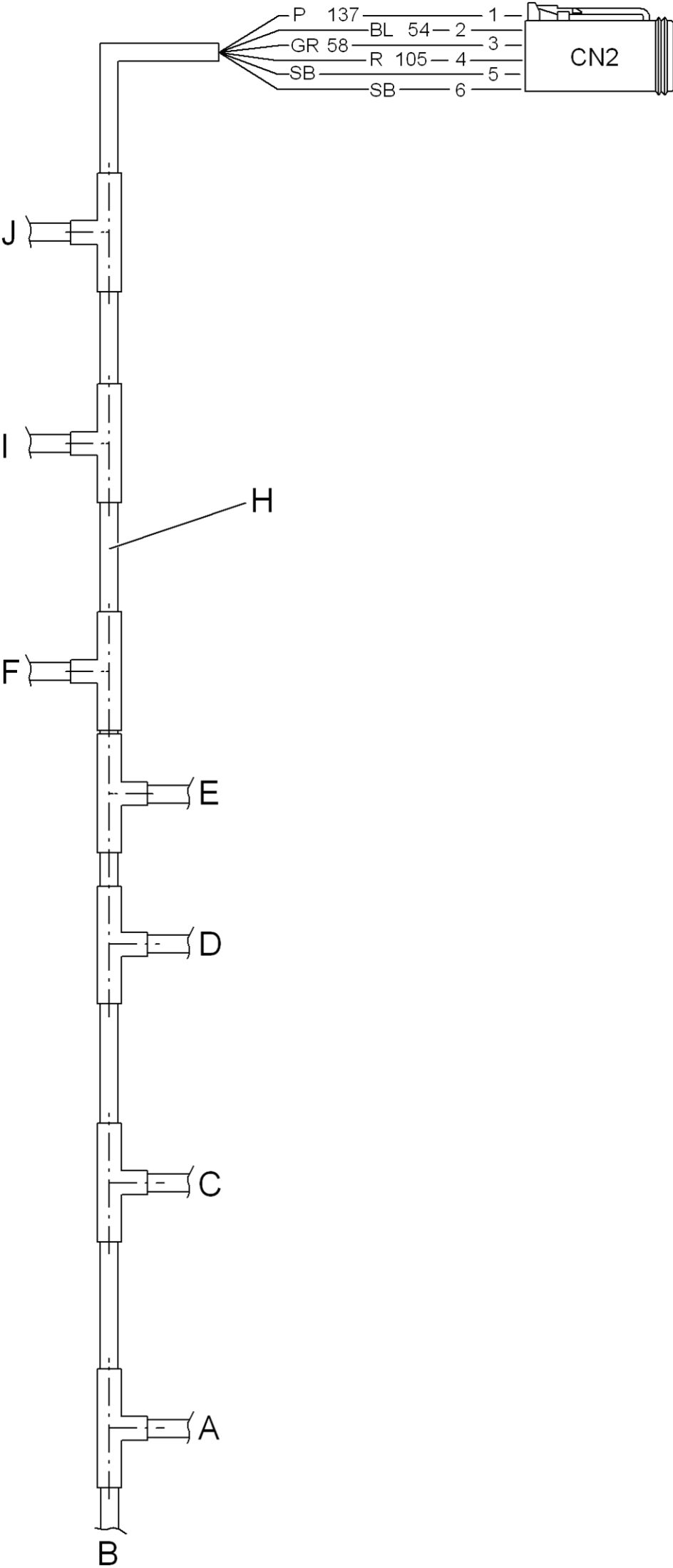



Construction Equipment

PROSIS Service Information

Document Title : Fuse box	Function Group : 371	Information Type : Service Information	Print Date : 19/10/2011
Profile : CEX, EC15B XTV (Volvo) [GB]			

Fuse box

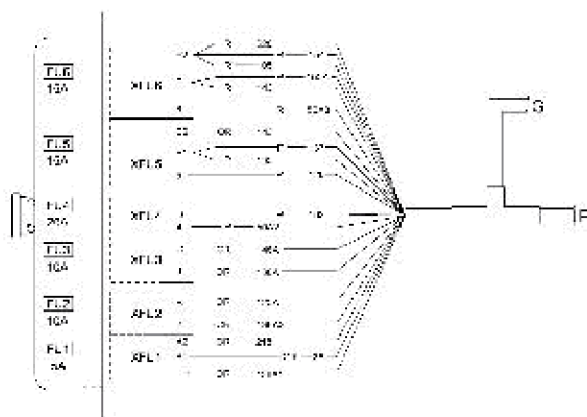
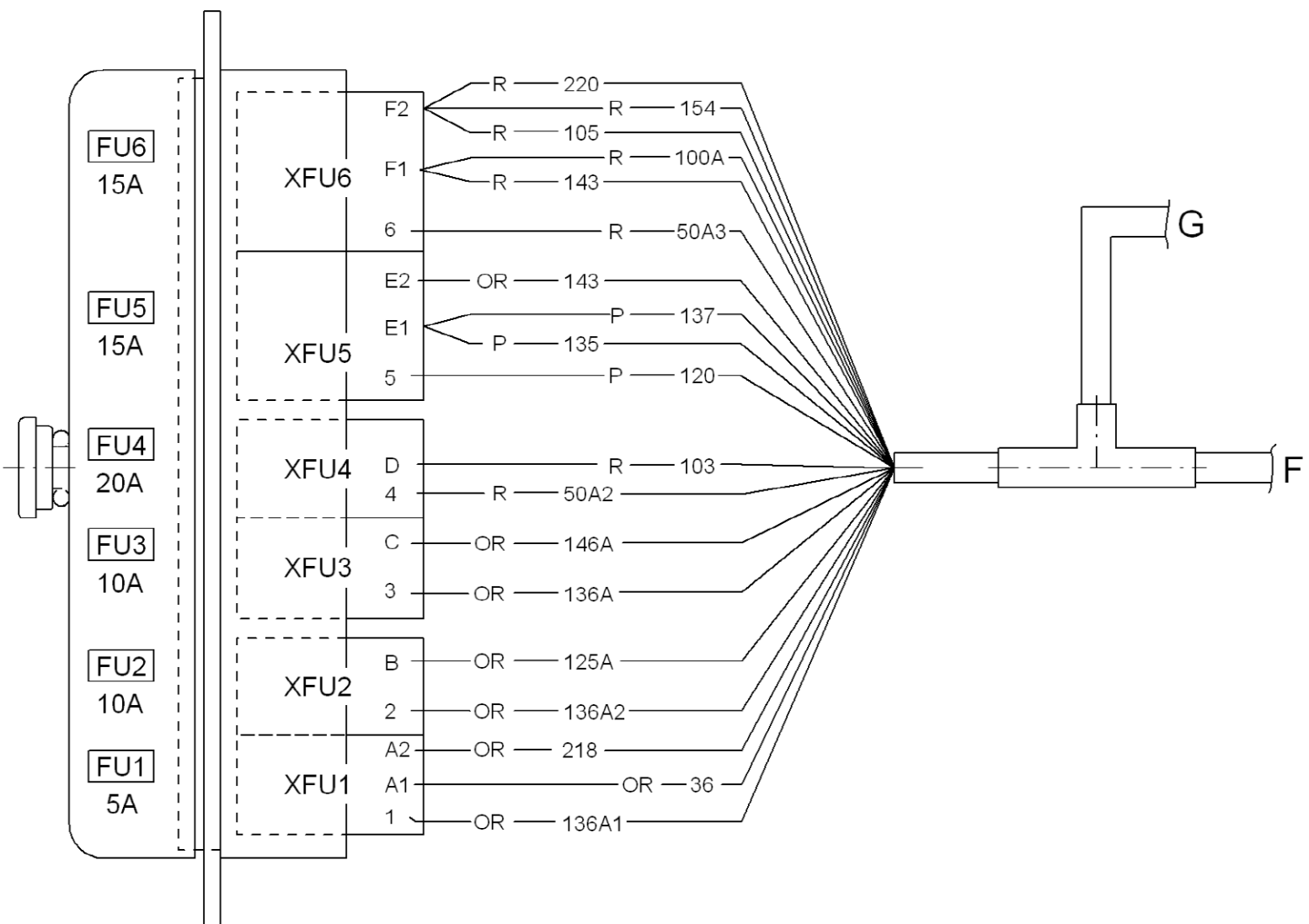

Figure 1

- F To main wiring loom point F
- G To wiring loom for main fuses FH1, FH2, point G





Construction Equipment

PROSIS Service Information

Document Title : Solenoid valve, slewing/offsetting	Function Group : 371	Information Type : Service Information	Print Date : 19/10/2011
Profile : CEX, EC15B XTV (Volvo) [GB]			

Solenoid valve, slewing/offsetting

Solenoid valve, variable track
headlights for boom
warning horn

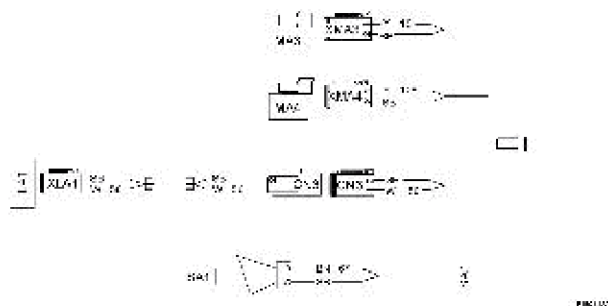
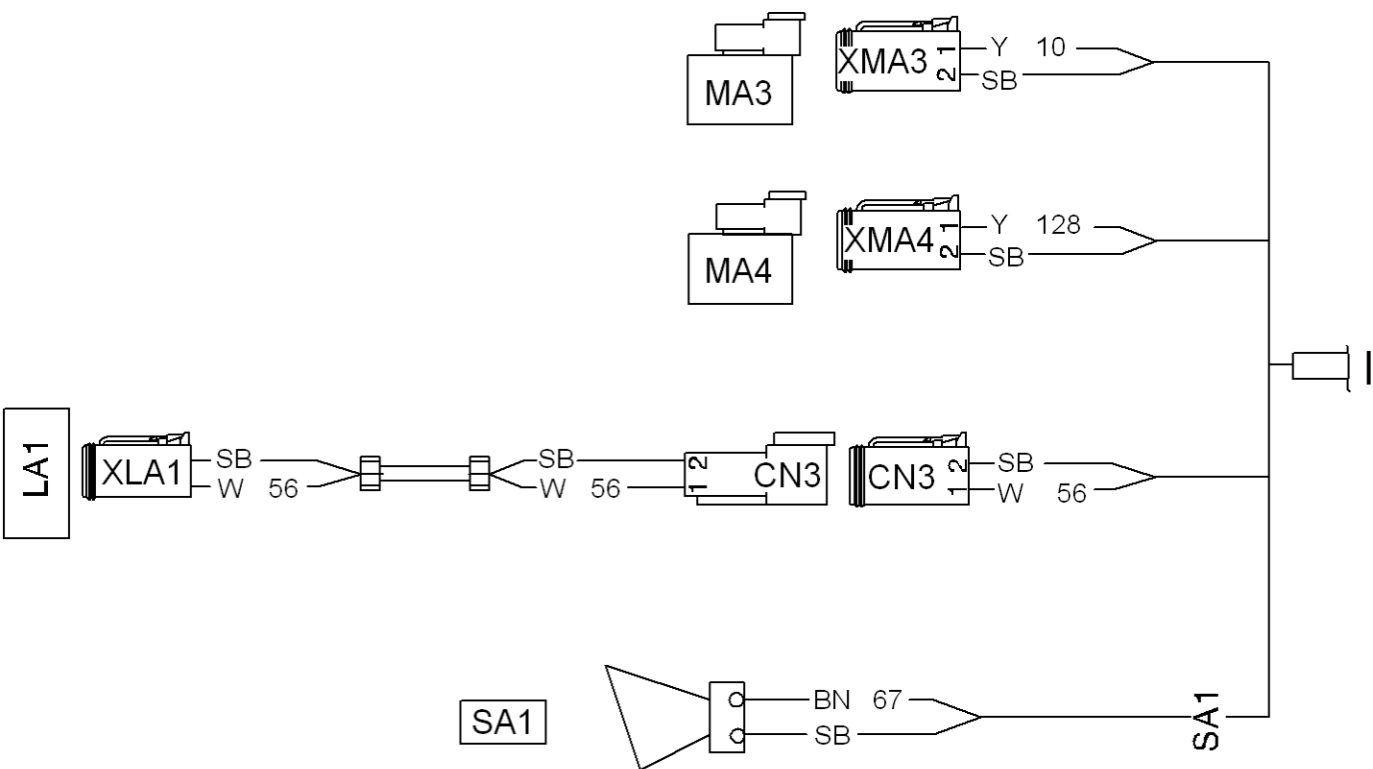

Figure 1

I To main wiring loom point I





Construction Equipment

PROSIS Service Information

Document Title : Console, left	Function Group : 371	Information Type : Service Information	Print Date : 19/10/2011
Profile : CEX, EC15B XTV (Volvo) [GB]			

Console, left

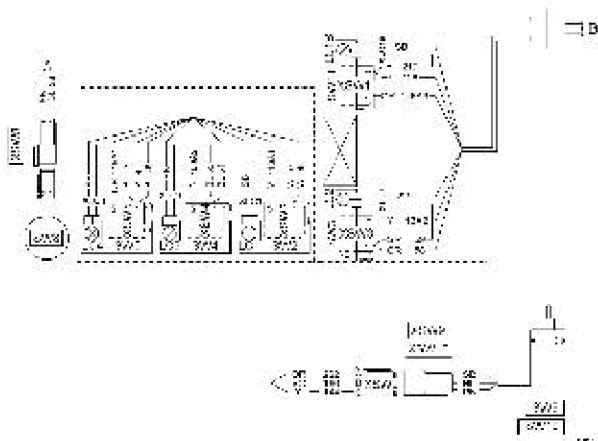
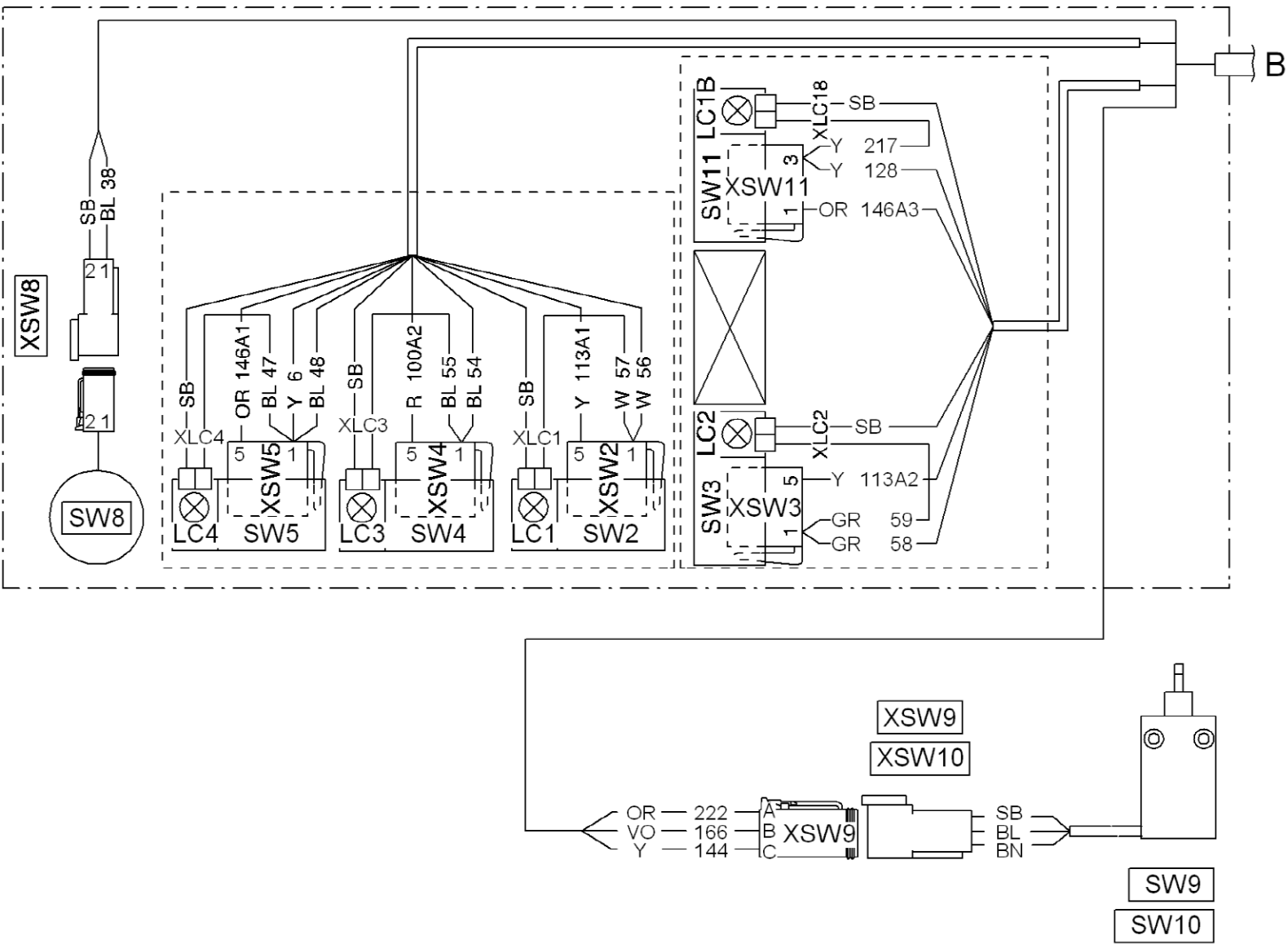

Figure 1

B To main wiring loom point **B**





Construction Equipment

PROSIS Service Information

Document Title : Console, right	Function Group : 371	Information Type : Service Information	Print Date : 19/10/2011
Profile : CEX, EC15B XTV (Volvo) [GB]			

Console, right

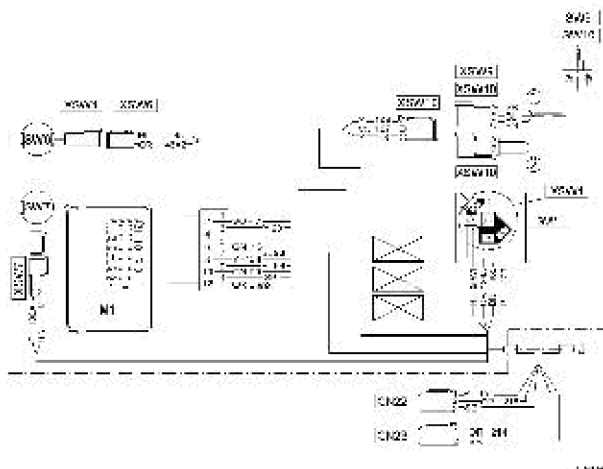
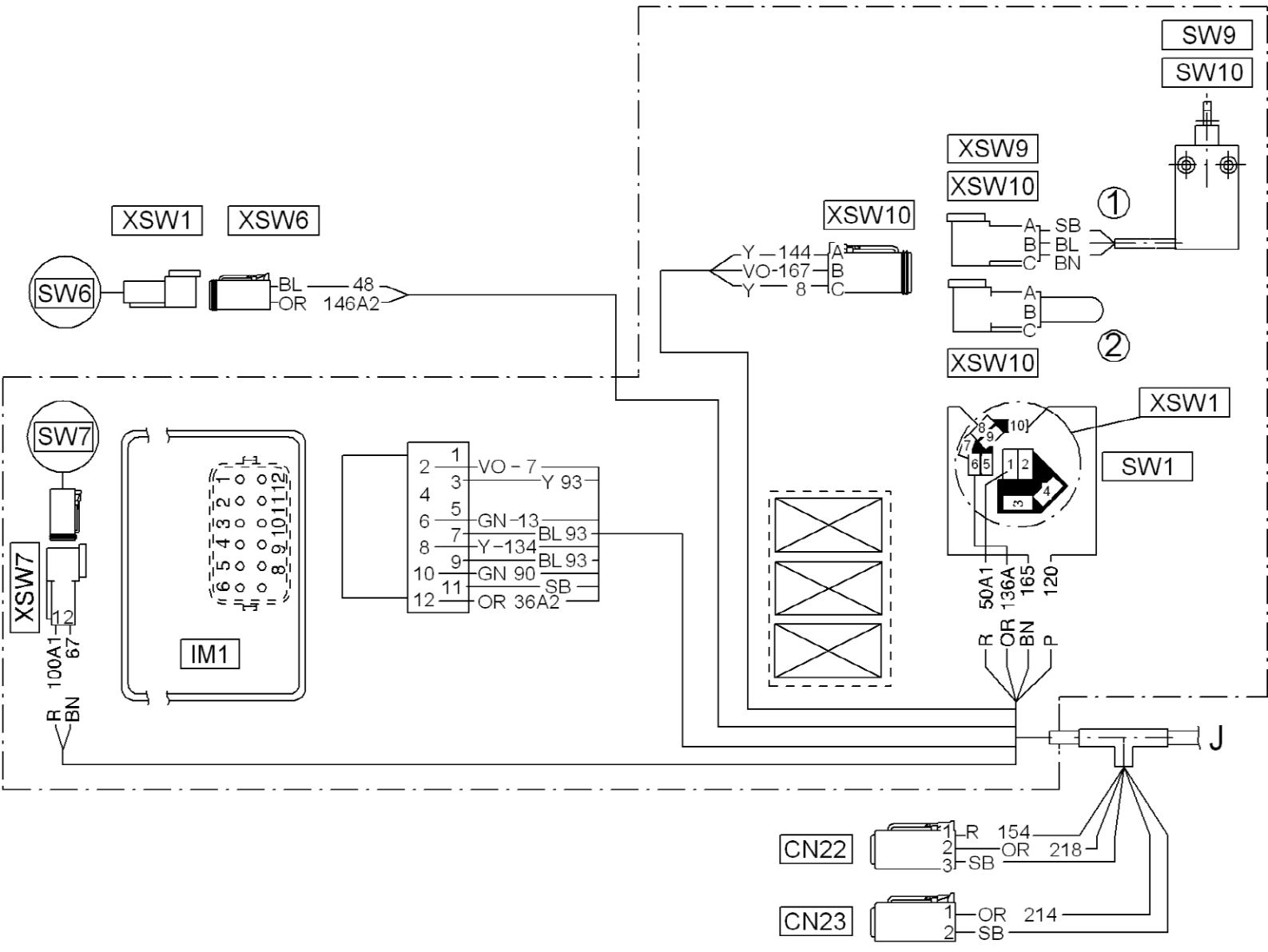

Figure 1

- J To main wiring loom point I
- 1 Safety switch, hydraulics variant 1
- 2 Safety switch, hydraulics variant 2





Construction Equipment

PROSIS Service Information

Document Title : Wiring looms	Function Group : 371	Information Type : Service Information	Print Date : 19/10/2011
Profile : CEX, EC15B XTV (Volvo) [GB]			

Wiring looms

Engine

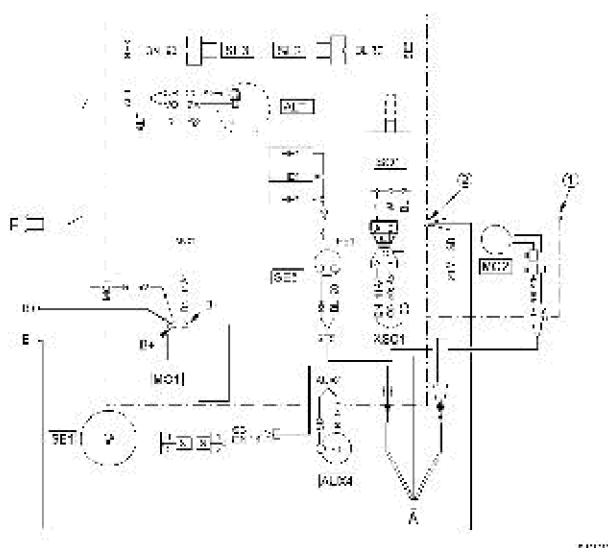

Figure 1

- 1 Ground connection, chassis
- 2 Ground connection, engine block
- A To main wiring loom point A
- E To main wiring loom point E