



Construction Equipment

PROSIS Service Information

Document Title : Main dimensions EC15B	Function Group : 000	Information Type : Service Information	Print Date : 19/10/2011
Profile : CEX, EC15B XTV (Volvo) [GB]			

Main dimensions EC15B

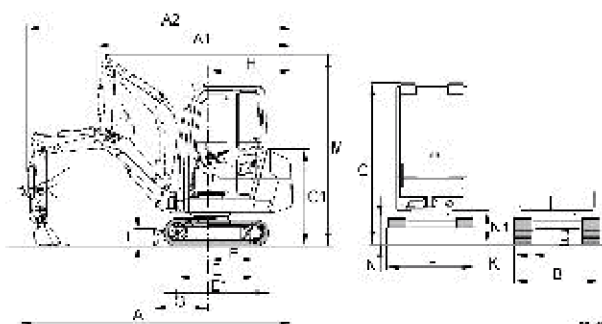
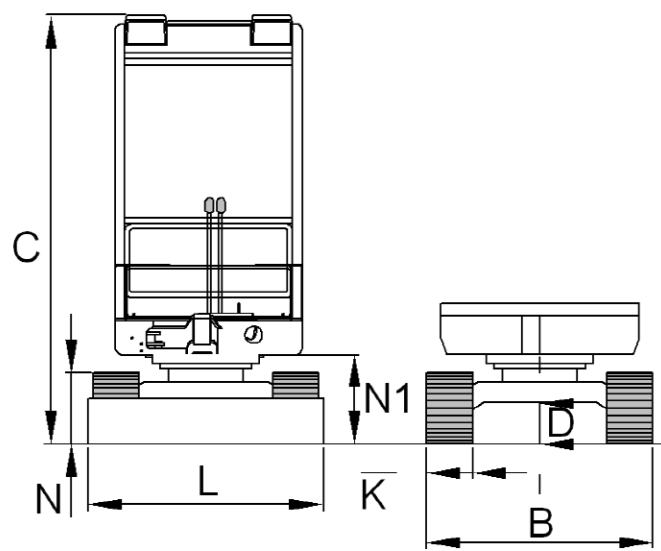
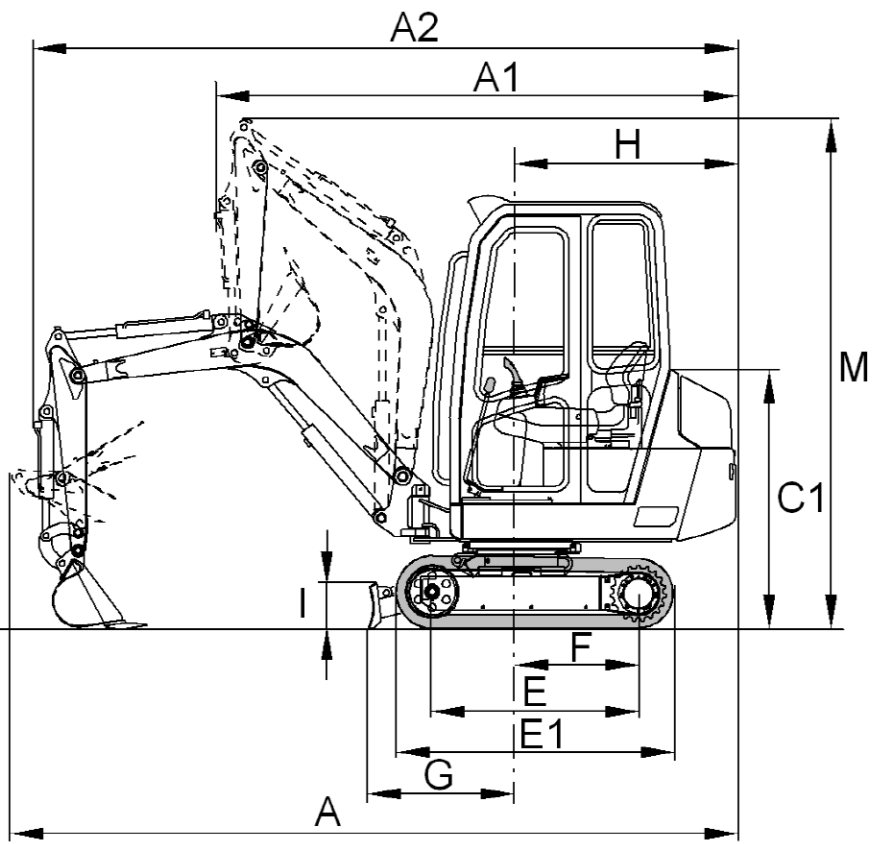

Figure 1
Dimensions of the machine

Machine				XR		XT		XTV	
		Symbol	Unit	Arm: 900	Arm: 1150	Arm: 900	Arm: 1150	Arm: 900	Arm: 1150
Overall height	Dozer blade	I	mm	243		240		243	
	Boom	M	mm	2652		2652		2671	
	Driver's cabin	C	mm	2270		2270		2292	
	Roll over protection structure	C	mm	2210		2210		2234	
	Engine cover	C1	mm	1370		1370		1370	
Ground clearance	Lower frame	D	mm	213		213		162	
	Superstructure	N1	mm	450		450		473	
Overall length		A	mm	3766	3771	3766	3771	3748	3765
Distance between chain sprockets		E	mm	1046		1085		1085	
Overall width	Boom raised	A1	mm	2659	2688	2659	2688	2659	2688
	Boom on Bucket	A2	mm	3649	3560	3649	3560	3665	3569
	Rotation point end of cabin	H	mm	1124		1124		1124	

Machine				XR		XT		XTV	
		Symbol	Unit	Arm: 900	Arm: 1150	Arm: 900	Arm: 1150	Arm: 900	Arm: 1150
Lower frame	Floor plate width	K	mm	230		230		230	
	Dozer plate width	L	only dozer blade	980		980		995	
			Dozer blade and extension	-		-		1345	
	Overall width	B	min.	980		980		986	
max.			1200		-		1336		

Machine			XR		XT		XTV	
	Symbol	Unit	Arm: 900	Arm: 1150	Arm: 900	Arm: 1150	Arm: 900	Arm: 1150
Length of track	E1	mm	1418		1467		1467	
Floor plate height	N	mm	373		397		397	
Rotation point - dozer blade	G	mm	857		856		876	
Rotation point - centre of sprocket	F	mm	603		620		620	





Construction Equipment

PROSIS Service Information

Document Title : Main dimensions EC20B	Function Group : 000	Information Type : Service Information	Print Date : 19/10/2011
Profile : CEX, EC15B XTV (Volvo) [GB]			

Main dimensions EC20B

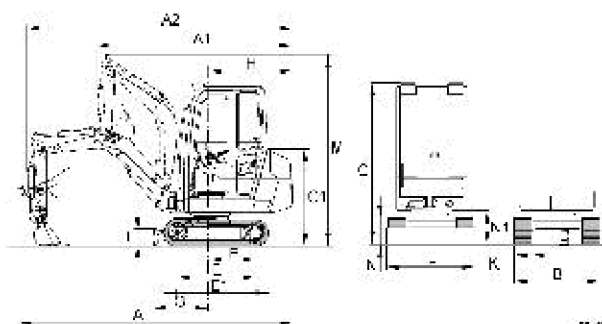
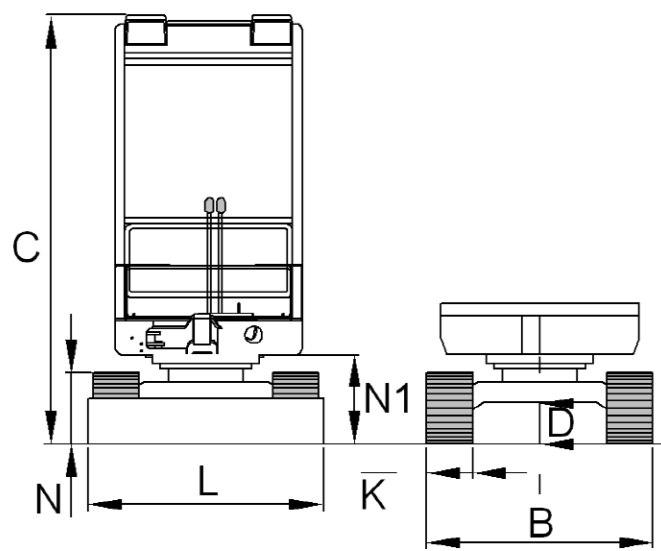
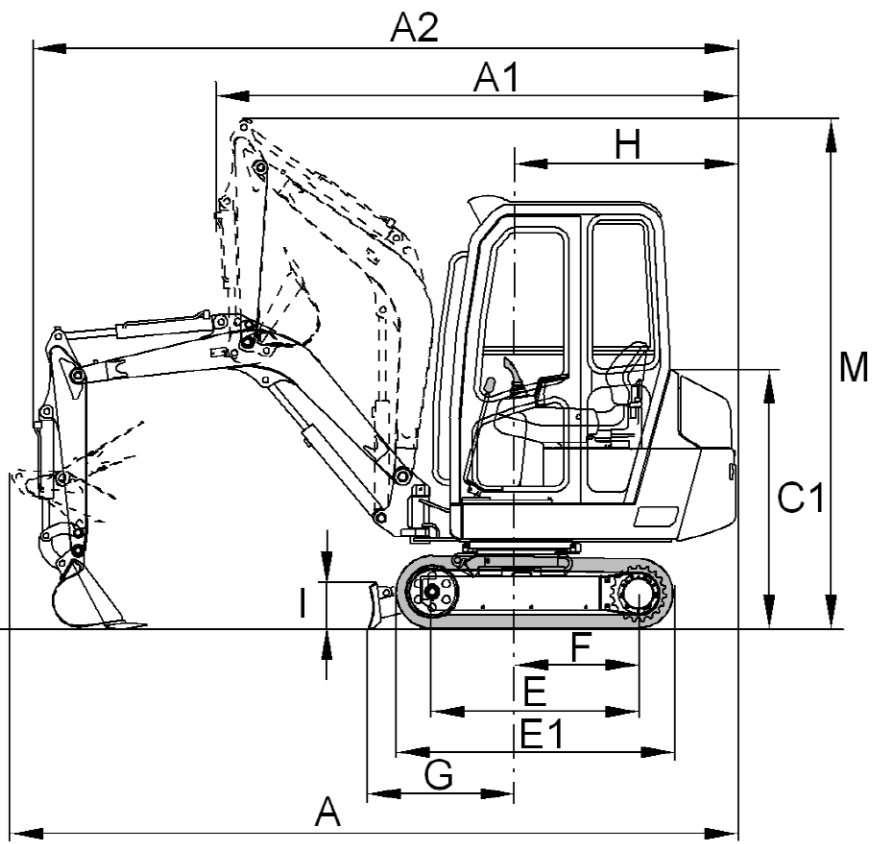

Figure 1
Dimensions of the machine

Machine				XT		XTV	
		Symbol	Unit	Arm: 1050	Arm: 1300	Arm: 1050	Arm: 1300
Overall height	Dozer blade	I	mm	261		242	
	Boom	M	mm	2865		2865	
	Driver's cabin	C	mm	2296		2296	
	Roll over protection structure	C	mm	2223		2223	
	Engine cover	C1	mm	1370		1370	
Ground clearance	Lower frame	D	mm	236		164	
	Superstructure	N1	mm	473		476	
Overall length		A	mm	3947	3974	3947	3974
Distance between chain sprockets		E	mm	1240		1240	
Overall width	Boom raised	A1	mm	2754	2790	2754	2790
	Boom on Bucket	A2	mm	3788	3664	3788	3664
	Rotation point end of cabin	H	mm	1124		1124	

Machine				XT		XTV	
		Symbol	Unit	Arm: 900	Arm: 1150	Arm: 900	Arm: 1150
Lower frame	Floor plate width	K	mm	250		250	
	Dozer plate width	L	only dozer blade	1200		995	
			Dozer blade and extension	-		1345	
	Overall width	B	min.	1200		1006	
			max.	-		1356	
	Length of track	E1	mm	1632		1632	
Floor plate height	N	mm	398		398		

Machine		XT		XTV		
	Symbol	Unit	Arm: 900	Arm: 1150	Arm: 900	Arm: 1150
Rotation point - dozer blade	G	mm	1074		976	
Rotation point - centre of sprocket	F	mm	660		660	





Construction Equipment

PROSIS Service Information

Document Title : Load capacity tables	Function Group : 020	Information Type : Service Information	Print Date : 19/10/2011
Profile : CEX, EC15B XTV (Volvo) [GB]			

Load capacity tables

- Rated handling loads in kg, i.e. 75% of the tipping load or 87% of the hydraulic limit. (* = hydraulic limit)
These loads apply for the complete height concerned (Z.), for the specified reach. Increase by 3% for steel tracks, except the values marked with * (hydraulic limits).

**WARNING!**

Transport of objects in lifting tackle operation is not permitted when the machine is supported by the dozer blade.

The specified values are valid for a machine:

- without attachment and without quick coupling.
If handling is accomplished in lifting gear operation with an assembled tool and/or assembled standard connecting system, the weight of these attachments must be subtracted from the values stated in the table.
- On level, compact ground.
- With full rotation of the superstructure.
- On rubber tracks.
Equipment parallel to the axis of the superstructure.
- With a 75 kg driver in the cab.



Construction Equipment

PROSIS Service Information

Document Title : Nominal lifting loads EC15B XR	Function Group : 020	Information Type : Service Information	Print Date : 19/10/2011
Profile : CEX, EC15B XTV (Volvo) [GB]			

Nominal lifting loads EC15B XR

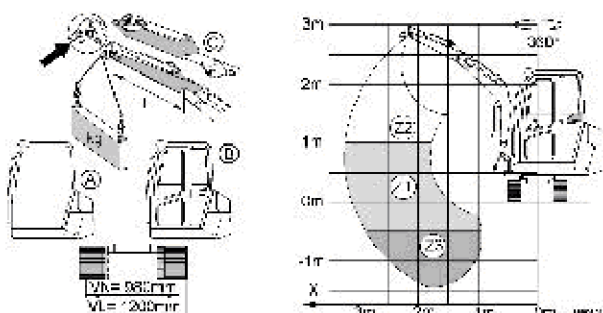

Figure 1

Load capacity tables

		[X]		[X]		[X]		[X]		[X]		[X]				
→X(m)		1		1.5		2		2.5		3		3.4 maxi		3.5 maxi		
		VN	VL	VN	VL	VN	VL	VN	VL	VN	VL	VN	VL	VN	VL	
A	L: 0.90 m	Z2				275	325*	205	250*	160	190					
		Z1	745*	745*	385	480	260	320	195	240	155	190				
		Z3	745*	745*	395	490	260	320	195	240						
	L: 1.15 m	Z2					280	325	190*	190*	160	185				
		Z1	610*	610*	385	455	260	300	195	225	155	180	130	150		
		Z3	610*	610*	385	455	260	300	195	225	155	175				
	C	Z2					255	305*	170*	170*	140	165				
		Z1	570*	570*	355	430	240	280	175	210	135	160			115	135
		Z3	570*	570*	360	440	240	285	175	210	135	165				
B	L: 0.90 m	Z2				325*	325*	240	250*	185	215					
		Z1	745*	745*	440	545	295	360	220	270	175	215				
		Z3	745*	745*	445	550	300	365	225	270						
	L: 1.15 m	Z2					320	365	190*	190*	180	210				
		Z1	610*	610*	435	510	295	340	220	255	175	200	150	170		
		Z3	610*	610*	440	515	295	340	220	255	175	200				
	C	Z2					290	305*	170*	170*	165	190				
		Z1	570*	570*	410	490	275	320	205	235	160	185			130	155
		Z3	570*	570*	410	495	275	325	205	240	160	190				[1]

◦ Rated handling loads in kg, i.e. 75 % of the tipping load or 87 % of the hydraulic limit (* = hydraulic limit). These loads apply for the complete height concerned (Z.), for the specified reach. Increase by 3 % for steel tracks, except the values marked with * (hydraulic limits).



WARNING!

Transport of objects in lifting gear operation is not permitted when the machine: – is supported by the dozer blade.

[1] (*) hydraulic limit

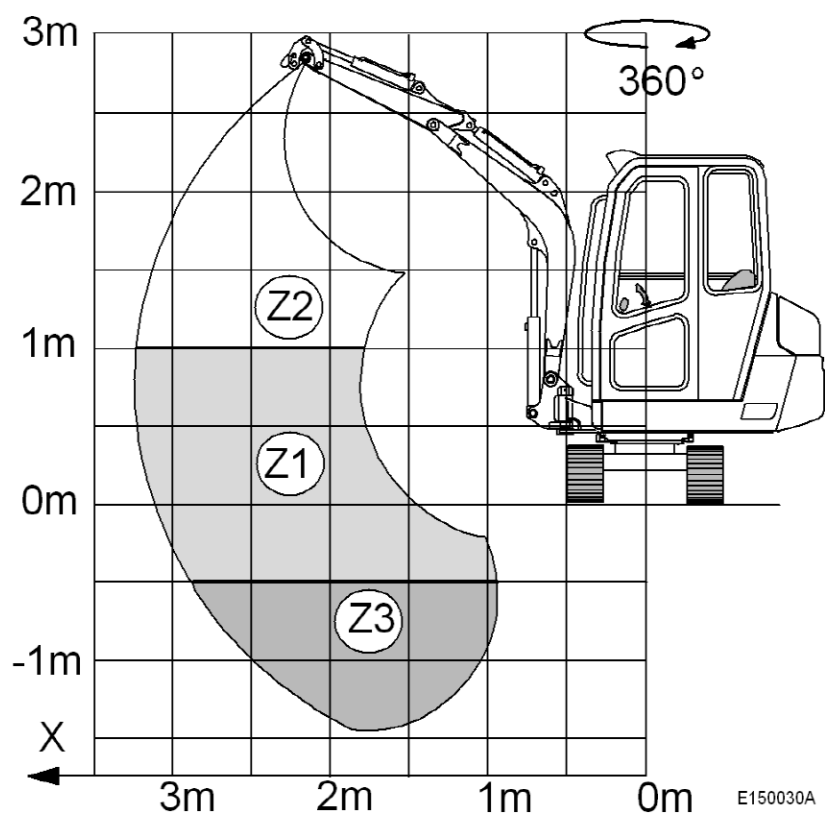
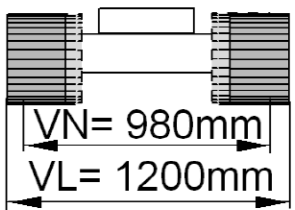
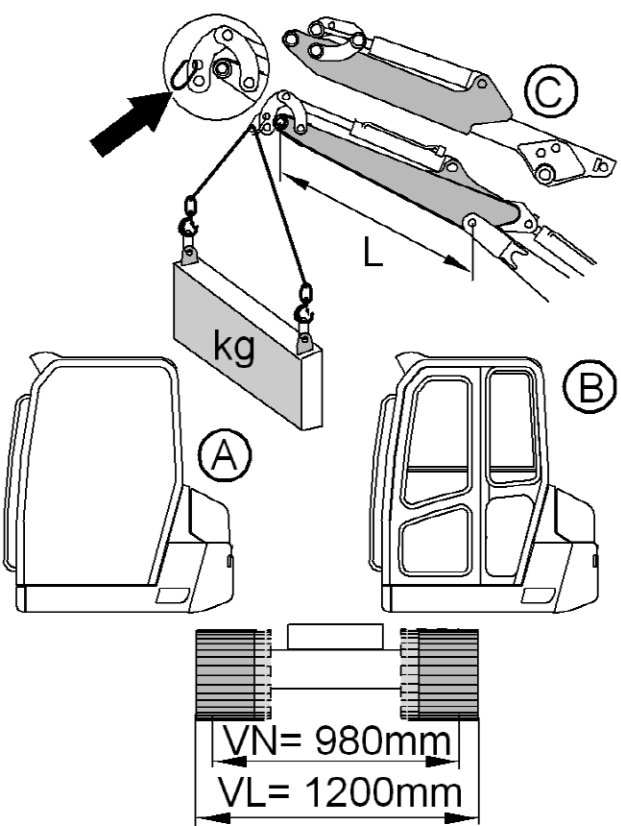



Construction Equipment

PROSIS Service Information

Document Title : Nominal lifting loads EC15B XT	Function Group : 020	Information Type : Service Information	Print Date : 19/10/2011
Profile : CEX, EC15B XTV (Volvo) [GB]			

Nominal lifting loads EC15B XT

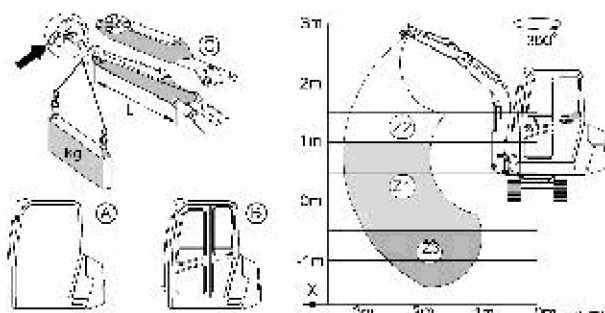

Figure 1

Load capacity tables

			✘	✘	✘	✘	✘	✘	✘
→X(m)		>	1	1.5	2	2.5	3	3.4 maxi	3.5 maxi
A	L: 0.90 m	Z2			285	210	165		
		Z1	745*	405	270	205	160		
		Z3	745*	410	275	205			
	L: 1.15 m	Z2			290	190*	165		
		Z1	610*	400	270	200	160	135	
		Z3	610*	405	270	200	160		
	C	Z2			270	170*	150		
		Z1	570*	380	255	185	145		120
		Z3	570*	385	255	185	145		
B	L: 0.90 m	Z2			325*	250*	200		
		Z1	745*	485	325	245	195		
		Z3	745*	495	330	245			
	L: 1.15 m	Z2			350	190*	200		
		Z1	610*	485	325	245	195	165	
		Z3	610*	485	325	245	195		
	C	Z2			305*	170*	170		
		Z1	570*	435	290	215	170		140
		Z3	570*	435	290	215	170		[1] ⓘ

- Rated handling loads in kg, i.e. 75 % of the tipping load or 87 % of the hydraulic limit (* = hydraulic limit). These loads apply for the complete height concerned (Z.), for the specified reach. Increase by 3 % for steel tracks, except the values marked with * (hydraulic limits).



WARNING!

Transport of objects in lifting gear operation is not permitted when the machine: – is supported by the dozer blade.

[1] (*) hydraulic limit

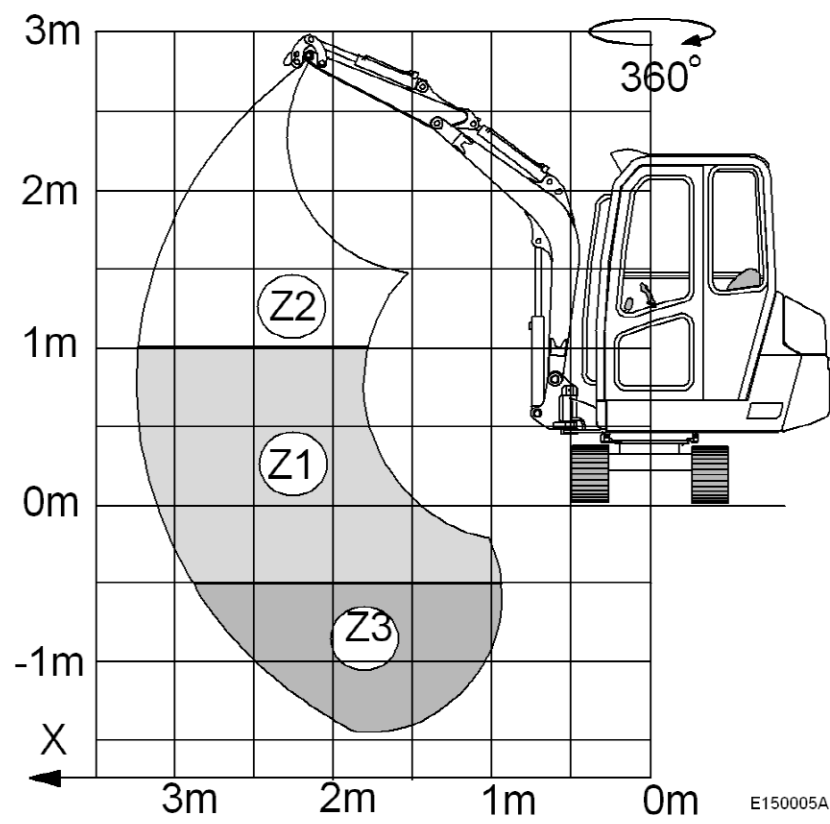
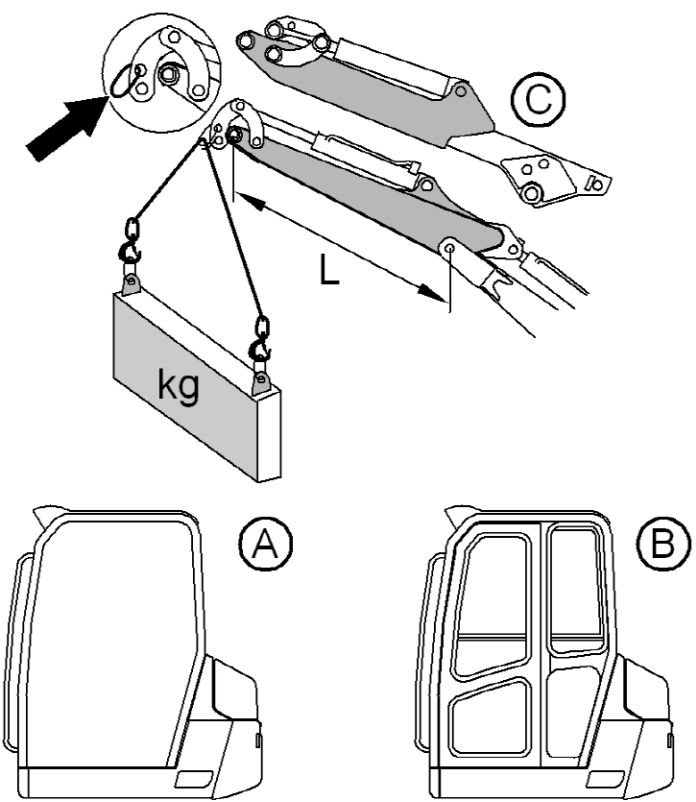



Construction Equipment

PROSIS Service Information

Document Title : Nominal lifting loads EC15B XTV	Function Group : 020	Information Type : Service Information	Print Date : 19/10/2011
Profile : CEX, EC15B XTV (Volvo) [GB]			

Nominal lifting loads EC15B XTV

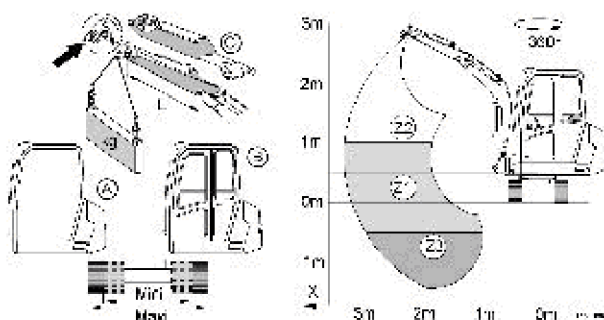

Figure 1

Load capacity tables

		[X]		[X]		[X]		[X]		[X]		[X]		[X]		
→X(m)		1		1.5		2		2.5		3		3.4 maxi		3.5 maxi		
		Mini	Maxi	Mini	Maxi	Mini	Maxi	Mini	Maxi	Mini	Maxi	Mini	Maxi	Mini	Maxi	
A	L: 0.90 m	Z2				315	330*	250	250*	180	210					
		Z1	760*	760*	450	530	300	350	225	260	180	205				
		Z3	760*	760*	460	535	305	350	230	260						
	L: 1.15 m	Z2					325	385*	190*	190*	185	210				
		Z1	610*	610*	450	525	300	350	225	260	180	205	155	175		
		Z3	610*	610*	450	530	300	350	225	260	180	205				
	C	Z2					310*	310*	175*	175*	165	180				
		Z1	580*	580*	420	460	280	305	205	225	160	175			135	145
		Z3	580*	580*	420	460	280	305	205	225	160	175				
B	L: 0.90 m	Z2				330*	330*	250*	250*	210	235					
		Z1	760*	760*	515	595	345	395	260	295	205	230				
		Z3	760*	760*	525	605	350	395	260	295						
	L: 1.15 m	Z2					370	385*	190*	190*	210	230*				
		Z1	610*	610*	515	590	345	385*	260	290	205	230	175	210		
		Z3	610*	610*	515	595	345	395	260	290	205	230				
	C	Z2					310*	310*	175*	175*	185	200*				
		Z1	580*	580*	475	515	315	345	235	255	185	200			150	165
		Z3	580*	580*	480	520	320	345	235	255	185	200				[1] ⓘ

◦ Rated handling loads in kg, i.e. 75 % of the tipping load or 87 % of the hydraulic limit (* = hydraulic limit). These loads apply for the complete height concerned (Z.), for the specified reach. Increase by 3 % for steel tracks, except the values marked with * (hydraulic limits).

**WARNING!**

Transport of objects in lifting gear operation is not permitted when the machine: – is supported by the dozer blade.

[1] (*) hydraulic limit

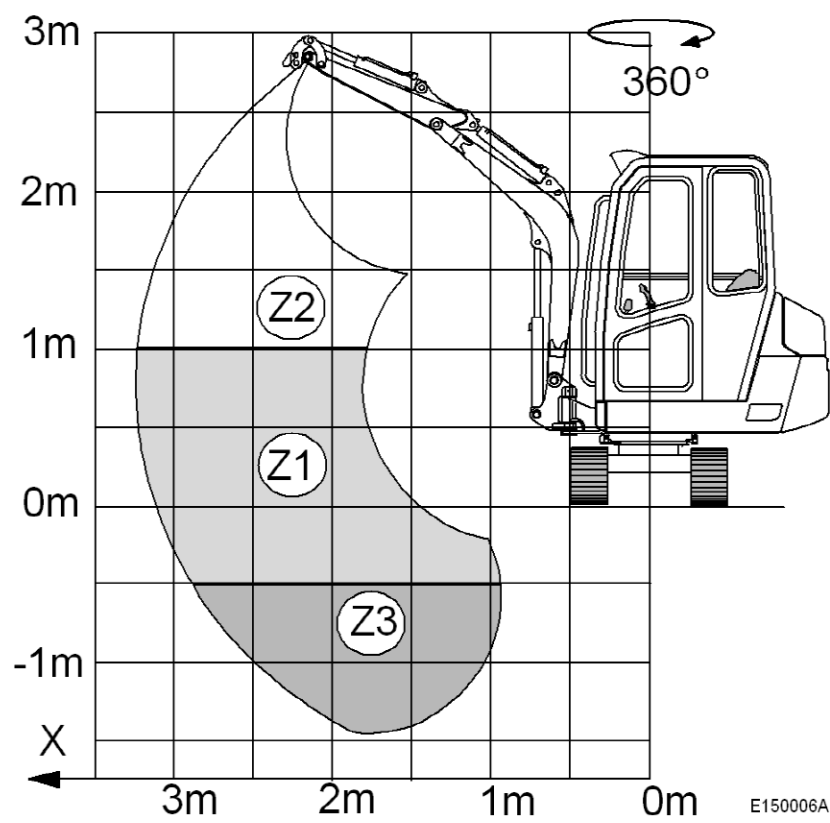
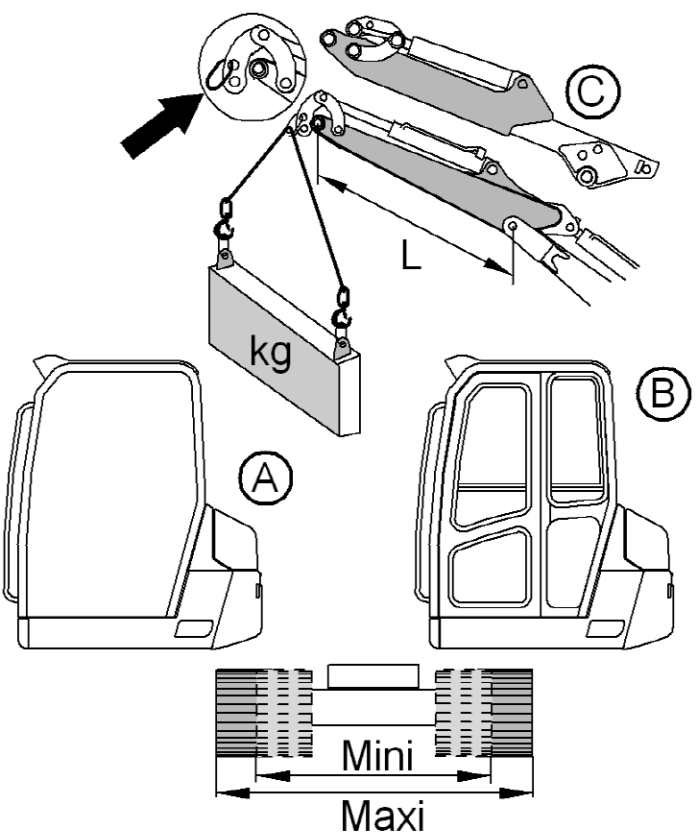



Construction Equipment

PROSIS Service Information

Document Title : Nominal lifting loads EC20B XT	Function Group : 020	Information Type : Service Information	Print Date : 19/10/2011
Profile : CEX, EC15B XTV (Volvo) [GB]			

Nominal lifting loads EC20B XT

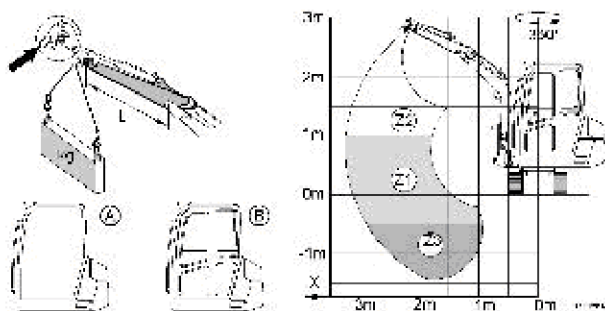

Figure 1

Load capacity tables

			✘	✘	✘	✘	✘	✘	✘
→X(m)		>	1	1.5	2	2.5	3	3.5	3.7 maxi
A	L: 1.05 m	Z2			395	285*	220		
		Z1	895*	580	375	275	215	175	
		Z3	895*	600	385	280			
	L: 1.30 m	Z2			420	305	235	185	
		Z1	755*	600	390	285	220	180	170
		Z3	755*	615	395	285	225		
B	L: 1.05 m	Z2			440*	285*	260		
		Z1	895*	675	440	325	255	210	
		Z3	895*	695	450	330			
	L: 1.30 m	Z2			470	320*	265*	210	
		Z1	755*	670	435	320	250	205	190
		Z3	755*	685	440	320	250		[1] ⓘ

- Rated handling loads in kg, i.e. 75 % of the tipping load or 87 % of the hydraulic limit (* = hydraulic limit). These loads apply for the complete height concerned (Z.), for the specified reach. Increase by 3 % for steel tracks, except the values marked with * (hydraulic limits).



WARNING!

Transport of objects in lifting gear operation is not permitted when the machine: – is supported by the dozer blade.

[1] (*) hydraulic limit

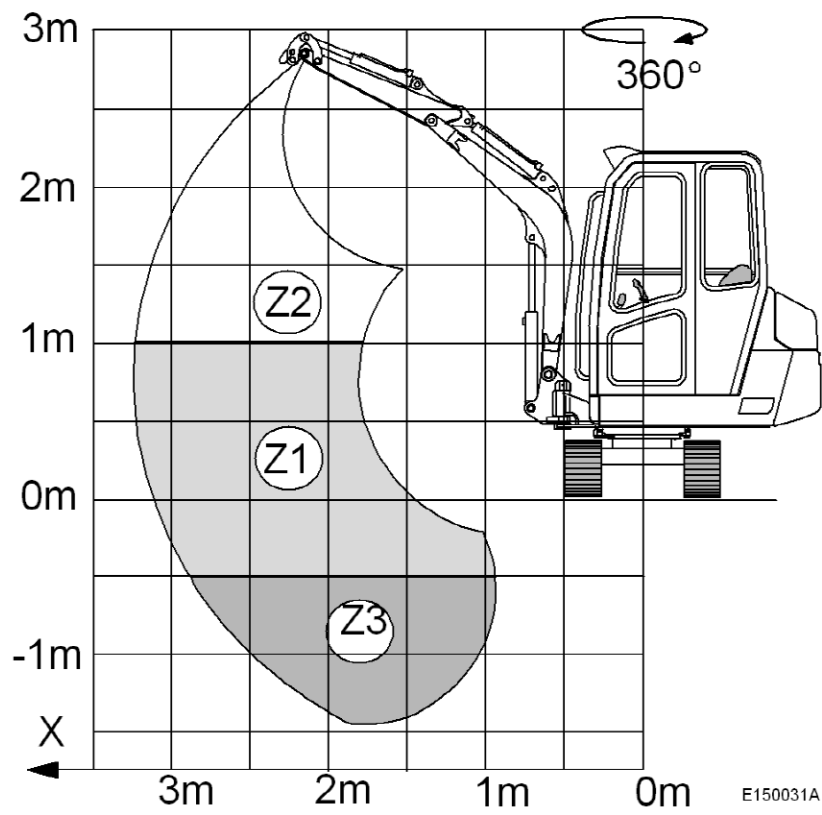
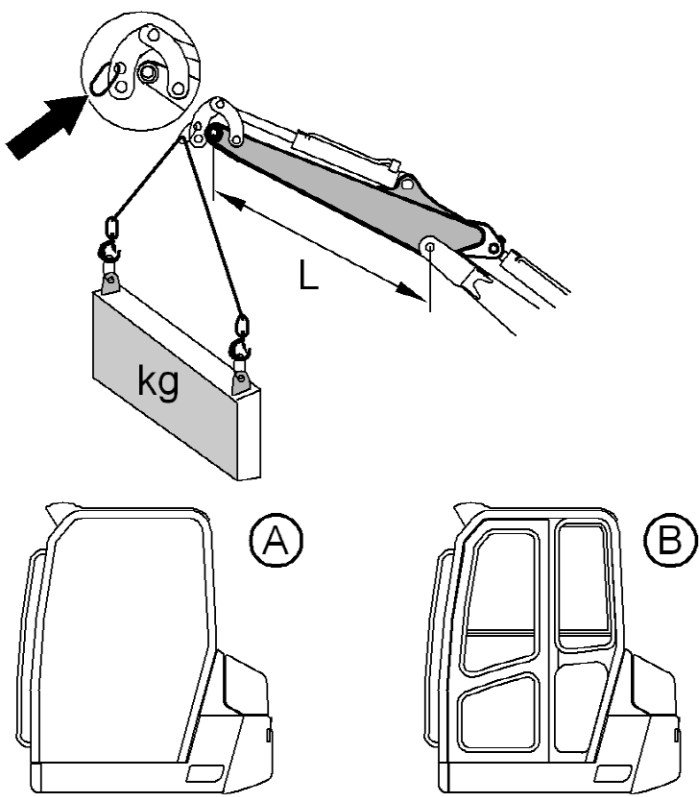



Construction Equipment

PROSIS Service Information

Document Title : Nominal lifting loads EC20B XTV	Function Group : 020	Information Type : Service Information	Print Date : 19/10/2011
Profile : CEX, EC15B XTV (Volvo) [GB]			

Nominal lifting loads EC20B XTV

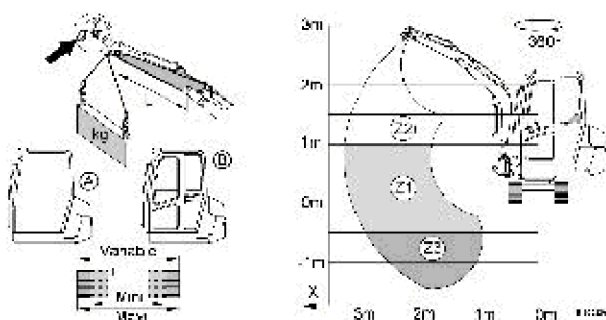

Figure 1

Load capacity tables

		[X]		[X]		[X]		[X]		[X]		[X]		[X]		
→X(m)		1		1.5		2		2.5		3		3.5		3.7 maxi		
		Mini	Maxi	Mini	Maxi	Mini	Maxi	Mini	Maxi	Mini	Maxi	Mini	Maxi	Mini	Maxi	
A	L: 1.05 m	Z2				330	440*	245	285*	185	290					
		Z1	895*	895*	465	765*	310	495	230	360	180	280	150	230		
		Z3	940	895*	480	805	320	505	235	365						
	L: 1.30 m	Z2					335	530*	245	320*	185	265*	150	230		
		Z1	755*	755*	460	795*	305	495	225	355	180	275	145	225	135	210
		Z3	920	755*	470	795	310	500	230	360	180	280				
B	L: 1.05 m	Z2				380	440*	280	285*	220	325*					
		Z1	895*	895*	540	765*	360	575	270	420	210	325	175	270		
		Z3	895*	895*	560	925	370	585	275	425						
	L: 1.30 m	Z2					390	530*	285	320*	220	265*	175	265		
		Z1	755*	755*	535	795*	360	570	265	415	210	320	170	260	160	245
		Z3	755*	755*	550	915	365	575	270	415	210	325				[1] ⓘ

- Rated handling loads in kg, i.e. 75 % of the tipping load or 87 % of the hydraulic limit (* = hydraulic limit). These loads apply for the complete height concerned (Z.), for the specified reach. Increase by 3 % for steel tracks, except the values marked with * (hydraulic limits).



WARNING!

Transport of objects in lifting gear operation is not permitted when the machine: – is supported by the dozer blade.

[1] (*) hydraulic limit

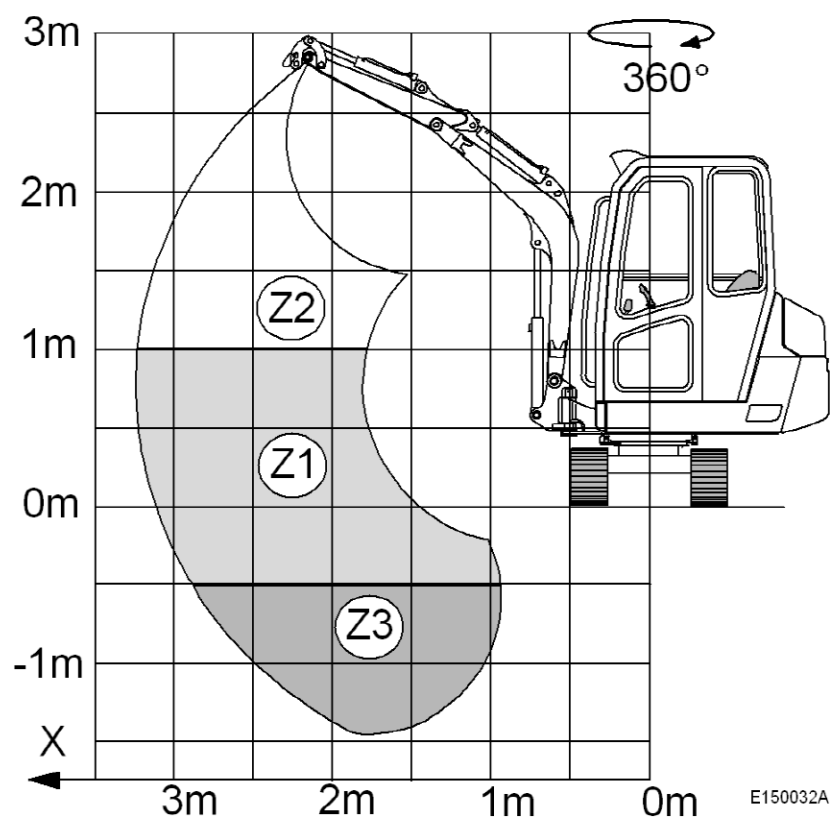
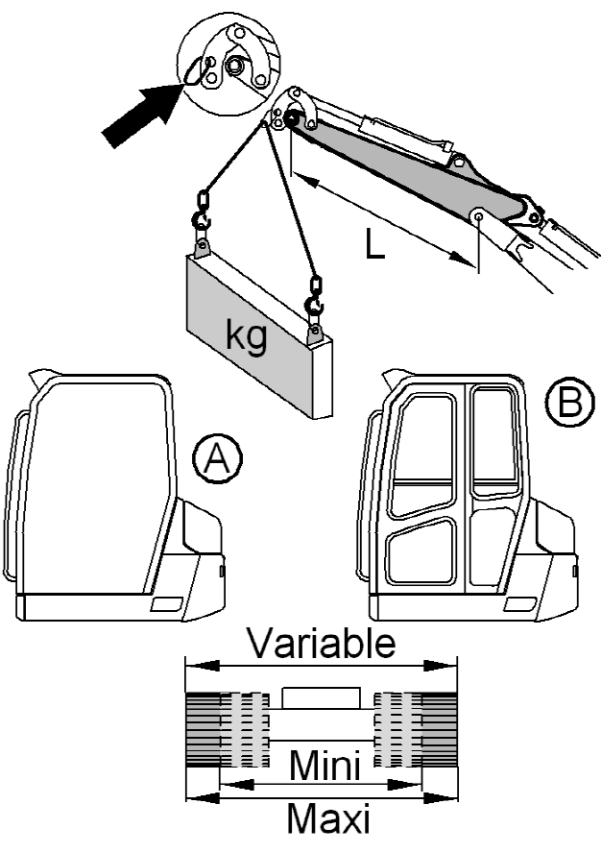



Construction Equipment

PROSIS Service Information

Document Title : Reach of the working attachment EC15B	Function Group : 020	Information Type : Service Information	Print Date : 19/10/2011
Profile : CEX, EC15B XTV (Volvo) [GB]			

Reach of the working attachment EC15B

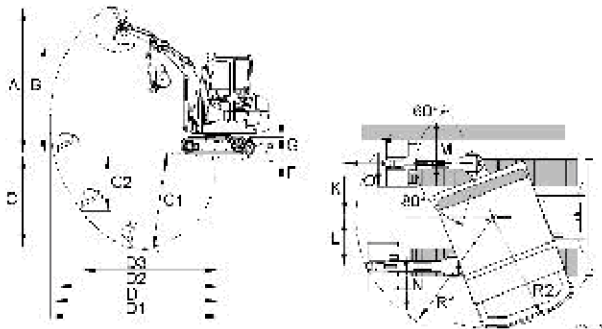
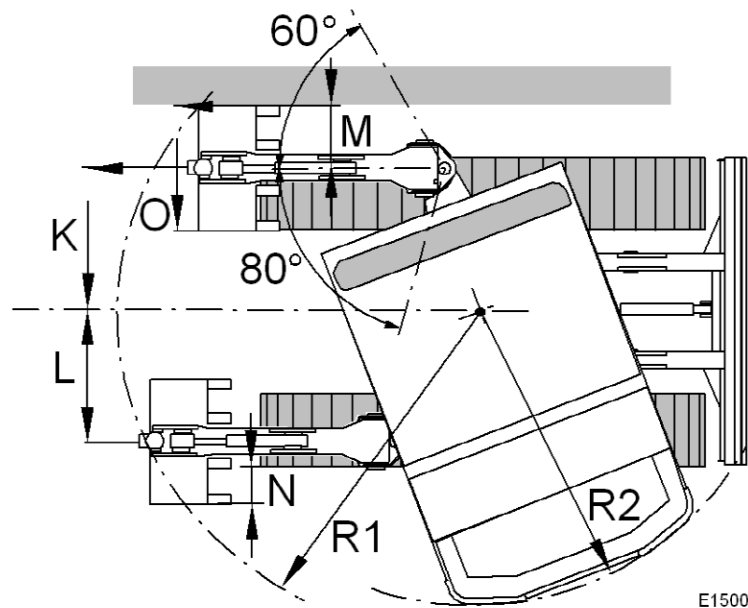
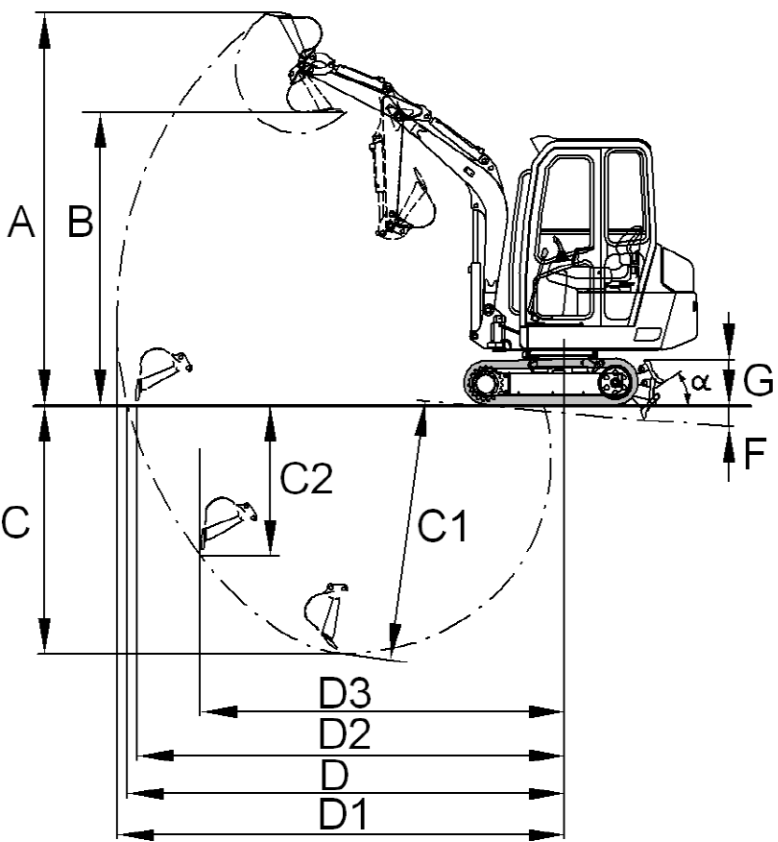

Figure 1





Construction Equipment

PROSIS Service Information

Document Title : Reach	Function Group : 020	Information Type : Service Information	Print Date : 19/10/2011
Profile : CEX, EC15B XTV (Volvo) [GB]			

Reach

Machine		XR		XT		XTV	
Excavator equipment	Unit	Arm: 900	Arm: 1150	Arm: 900	Arm: 1150	Arm: 900	Arm: 1150
A..	mm	3412	3553	3412	3553	3431	3572
B..	mm	2479	2620	2479	2620	2498	2639
C..	mm	2045	2295	2045	2295	2026	2276
C1	mm	2192	2441	2192	2441	2158	2408
C2	mm	1501	1741	1501	1741	1482	1721
D..	mm	3618	3858	3618	3858	3613	3853
D1	mm	3719	3952	3719	3952	3719	3952
D2	mm	3579	3816	3579	3816	3576	3812
D3	mm	2674	2745	2674	2745	2674	2745
F..	mm	190		190		175	
G..	mm	420		420		434	
K	mm	550		550		550	
L	mm	460		460		460	
M	mm	260		260		257	
M. extension to max.	mm	-		-		82	

Reach

Machine		XR		XT		XTV	
Excavator equipment	Unit	Arm: 900	Arm: 1150	Arm: 900	Arm: 1150	Arm: 900	Arm: 1150
N	mm	170		170		166	
N. extension to max.	mm	-		-		9	
O.	mm	400		400		400	
R1	mm	1382	1413	1382	1413	1382	1413
R2	mm	1162		1162		1162	

Slewing range

Machine	XR		XT		XTV	
Boom offset angle	a1 = 59°	a2 = 75°	a1 = 59°	a2 = 75°	a1 = 56°	a2 = 75°
Total slewing range	360°					

Bucket performances

Digging force	1510 daN
Tear-out force	960 daN



Construction Equipment

PROSIS Service Information

Document Title : Reach of the working attachment EC20B	Function Group : 020	Information Type : Service Information	Print Date : 19/10/2011
Profile : CEX, EC15B XTV (Volvo) [GB]			

Reach of the working attachment EC20B

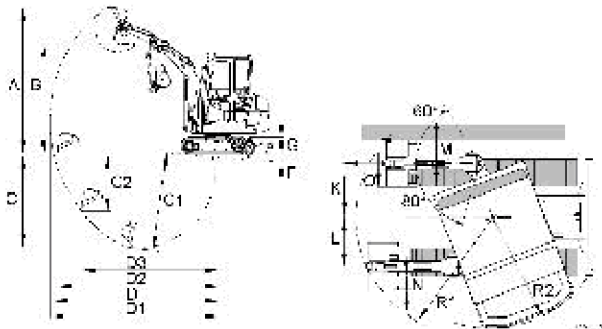
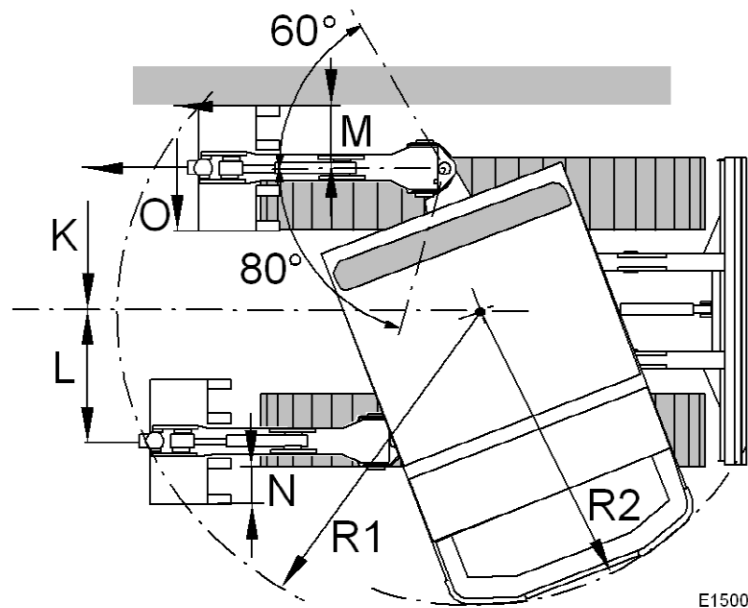
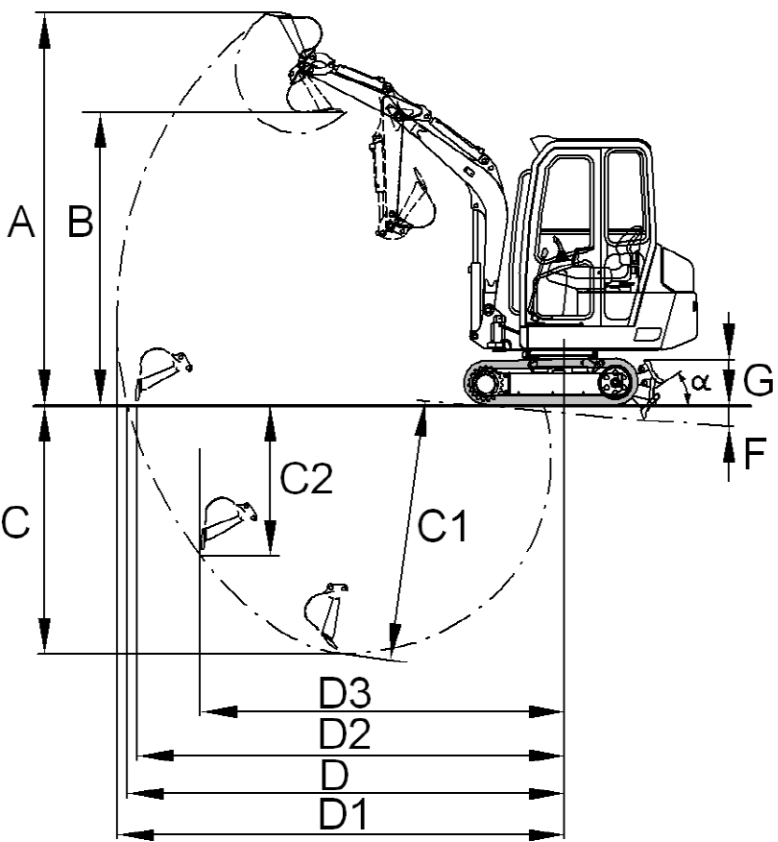

Figure 1





Construction Equipment

PROSIS Service Information

Document Title : Reach	Function Group : 020	Information Type : Service Information	Print Date : 19/10/2011
Profile : CEX, EC15B XTV (Volvo) [GB]			

Reach

Machine		XT		XTV	
Excavator equipment	Unit	Arm: 1050	Arm: 1300	Arm: 1050	Arm: 1300
A..	mm	3753	3898	3753	3898
B..	mm	2673	2818	2673	2818
C..	mm	2342	2592	2342	2592
C1	mm	2546	2795	2514	2764
C2	mm	1574	1804	1574	1804
D..	mm	4017	4258	4017	4258
D1	mm	4113	4347	4113	4347
D2	mm	3964	4202	3964	4202
D3	mm	3153	3252	3153	3252
F..	mm	275		222	
G..	mm	472		457	
K	mm	550		550	
L	mm	460		460	
M	mm	200		297	

Reach

Machine		XT		XTV	
Excavator equipment	Unit	Arm: 1050	Arm: 1300	Arm: 1050	Arm: 1300
M. extension to max.	mm	-		122	
N	mm	110		206	
N. extension to max.	mm	-		31	
O.	mm	500		500	
R1	mm	1475	1509	1475	1509
R2	mm	1162		1162	

Slewing range

Machine	XT		XTV	
Boom offset angle	a1 = 60°	a2 = 80°	a1 = 60°	a2 = 80°
Total slewing range				

Bucket performances

Digging force	1850 daN
Tear-out force	1250 daN



Construction Equipment

PROSIS Service Information

Document Title : Warning and information decals	Function Group : 020	Information Type : Service Information	Print Date : 19/10/2011
Profile : CEX, EC15B XTV (Volvo) [GB]			

Warning and information decals

The driver must be acquainted with and observe all warning and information decals, which are attached to the machine.

- Stickers and decals, which are missing or have been damaged, must be immediately replaced.
- Apart from that the decals must be kept in a legible, i.e. clean condition.
- The spare parts number (ordering number) is printed on the respective decal or can be found in the spare parts catalogue.



Construction Equipment

PROSIS Service Information

Document Title : Caution sign - Operation and maintenance	Function Group : 020	Information Type : Service Information	Print Date : 19/10/2011
Profile : CEX, EC15B XTV (Volvo) [GB]			

Caution sign - Operation and maintenance

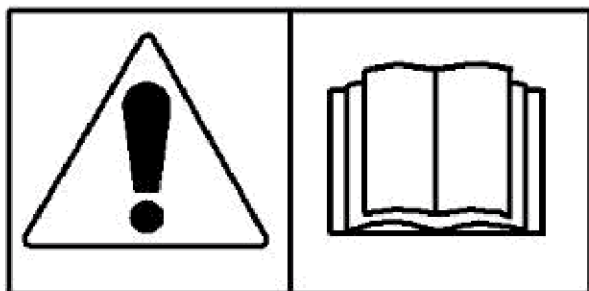

E250487A

Figure 1

The instructions and warnings in the operating manual must be read carefully before using the machine for the first time. The technical documentation can be found in the storage compartment under the driver's seat.



Construction Equipment

PROSIS Service Information

Document Title : Warning sign - Open engine hood only with engine stopped	Function Group : 020	Information Type : Service Information	Print Date : 19/10/2011
Profile : CEX, EC15B XTV (Volvo) [GB]			

Warning sign - Open engine hood only with engine stopped



E25D4BBA

Figure 1

Due to the risk of injury by rotating parts it is dangerous to open the engine hood while the engine is running.



Construction Equipment

PROSIS Service Information

Document Title : Warning sign - Safety distance from the work area	Function Group : 020	Information Type : Service Information	Print Date : 19/10/2011
Profile : CEX, EC15B XTV (Volvo) [GB]			

Warning sign - Safety distance from the work area

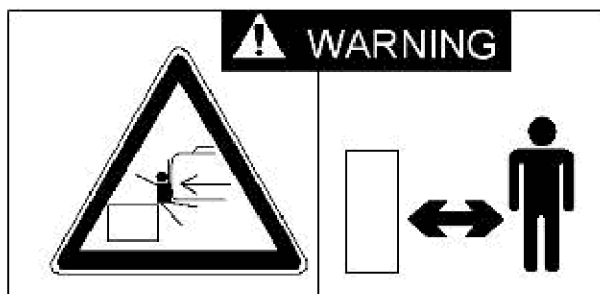

Figure 1

It shows that a sufficient safety distance to the action range of the machine must be maintained to avoid injury.



Construction Equipment

PROSIS Service Information

Document Title : Warning sign - Safety distance from the movement area	Function Group : 020	Information Type : Service Information	Print Date : 19/10/2011
Profile : CEX, EC15B XTV (Volvo) [GB]			

Warning sign - Safety distance from the movement area



E250490A

Figure 1

This sticker indicates that a sufficient safety distance to the movement zone of the wheel loader arm must be maintained, in order to rule out any danger of injury.



Construction Equipment

PROSIS Service Information

Document Title : Caution sign - Track tension	Function Group : 020	Information Type : Service Information	Print Date : 19/10/2011
Profile : CEX, EC15B XTV (Volvo) [GB]			

Caution sign - Track tension

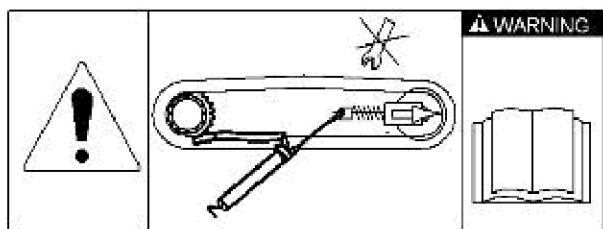

E250491A

Figure 1

Sticker stuck to the cabin roof inside the cab.
It indicates that the tension of the tracks must be checked every day.



Construction Equipment

PROSIS Service Information

Document Title : Caution sign - Diesel engine starting procedure	Function Group : 020	Information Type : Service Information	Print Date : 19/10/2011
Profile : CEX, EC15B XTV (Volvo) [GB]			

Caution sign - Diesel engine starting procedure

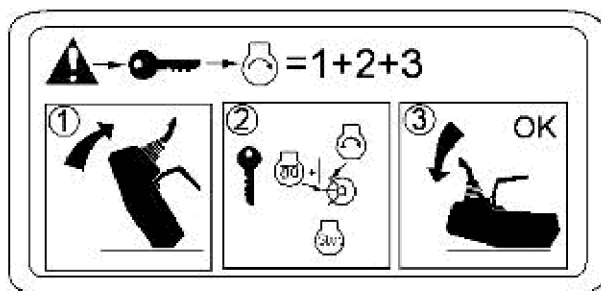

E250492A

Figure 1

Sticker stuck to the cabin roof inside the cab.
It indicates the starting procedure for the diesel engine.



Construction Equipment

PROSIS Service Information

Document Title : Caution sign - Lifting the machine	Function Group : 020	Information Type : Service Information	Print Date : 19/10/2011
Profile : CEX, EC15B XTV (Volvo) [GB]			

Caution sign - Lifting the machine

Sticker stuck to the cabin roof inside the cab.

It indicates that only these specific lifting points must be used to lift the machine.



Construction Equipment

PROSIS Service Information

Document Title : Caution sign - Lashing	Function Group : 020	Information Type : Service Information	Print Date : 19/10/2011
Profile : CEX, EC15B XTV (Volvo) [GB]			

Caution sign - Lashing

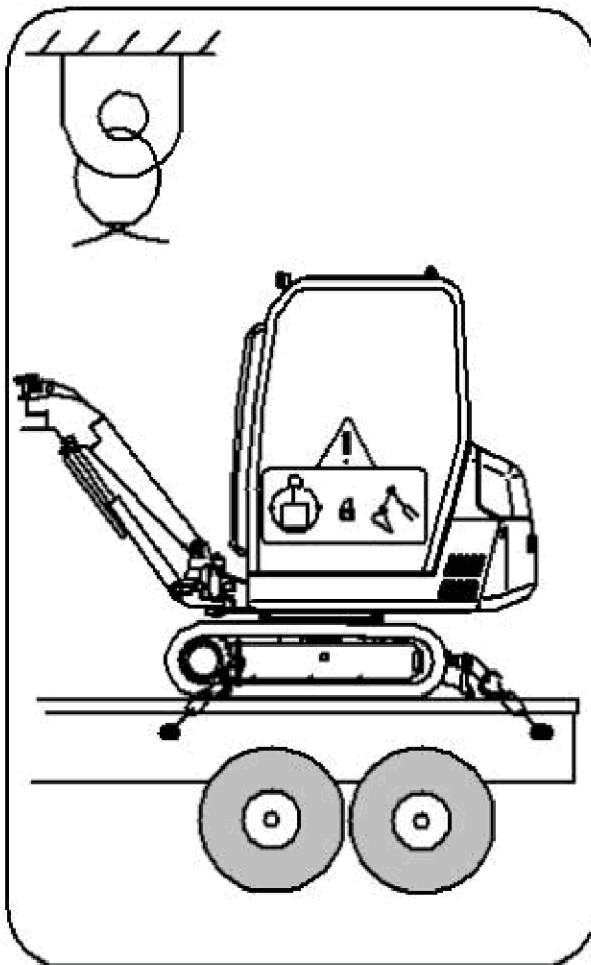

E250494A

Figure 1

Sticker stuck to the cabin roof inside the cab.
It indicates that only these fastening points must be used.

VOLVO

Construction Equipment

PROSIS Service Information

Document Title : Caution sign - Emergency exit	Function Group : 020	Information Type : Service Information	Print Date : 19/10/2011
Profile : CEX, EC15B XTV (Volvo) [GB]			

Caution sign - Emergency exit

**E250495A**

Figure 1

Sticker stuck to the rear windscreen of the cabin indicating the location of the emergency exit (the window must be smashed with the hammer provided for this purpose and stored inside a support on the rear cabin wall).



Construction Equipment

PROSIS Service Information

Document Title : Machine identification	Function Group : 020	Information Type : Service Information	Print Date : 19/10/2011
Profile : CEX, EC15B XTV (Volvo) [GB]			

Machine identification

The following illustration and description shows which identification plates are on the machine.

When ordering spare parts or in case of enquiries by phone or in writing the model designation and the product identification number must be specified.

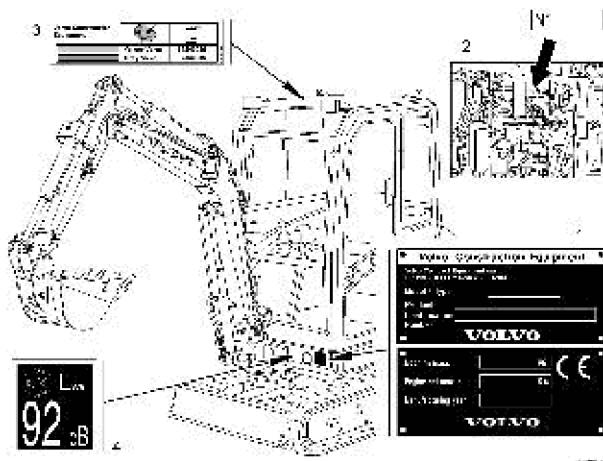

Figure 1
Machine identification

1. Product plate with product identification number for the complete machine, model designation, weight of machine, engine power and year of manufacture. The plate is located on the front of the rotating chassis.
2. The identification of the engine is inscribed on the rocker arm cover.
3. Spray finish, cabin type, type approval and serial number can be found on the rear roof beam of the cabin.
4. Sound capacity of the machine [1] ⓘ

[1] On type EC20B 93 dB

3

Volvo Construction Equipment		
	Yellow Volvo	E2340086
	Grey Volvo	E2340085

E2340084

N°

2

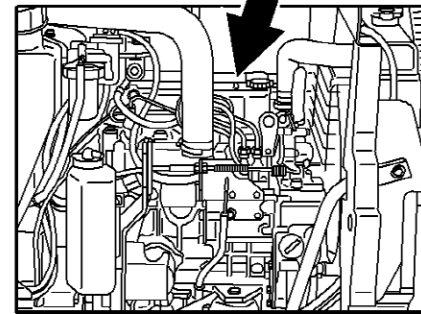

1

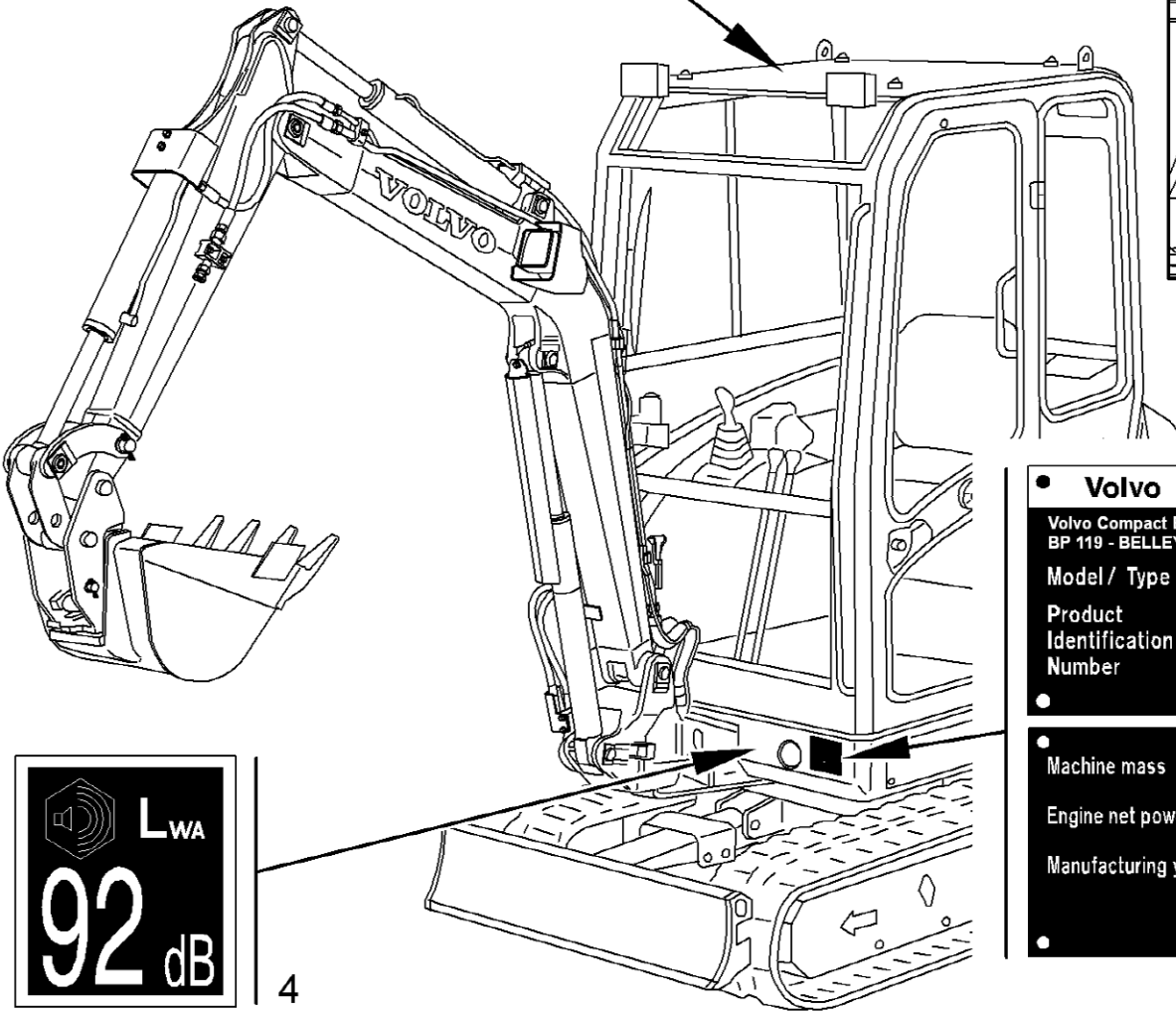

• Volvo Construction Equipment •

Volvo Compact Equipment sas
BP 119 - BELLEY Cedex - FRANCE

Model / Type

Product Identification Number

VOLVO

Machine mass KG 

Engine net power KW

Manufacturing year

VOLVO



LWA

92 dB

4



Construction Equipment

PROSIS Service Information

Document Title : Identification of the engine	Function Group : 020	Information Type : Service Information	Print Date : 19/10/2011
Profile : CEX, EC15B XTV (Volvo) [GB]			

Identification of the engine

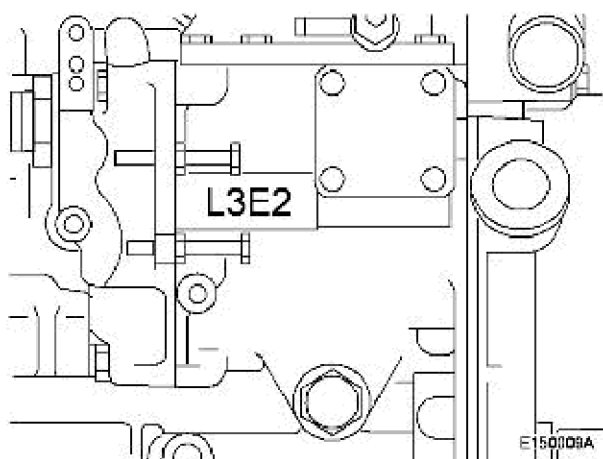

Figure 1

The identification of the engine is stamped on the right hand side of the engine block near the injection pump mounting bracket.

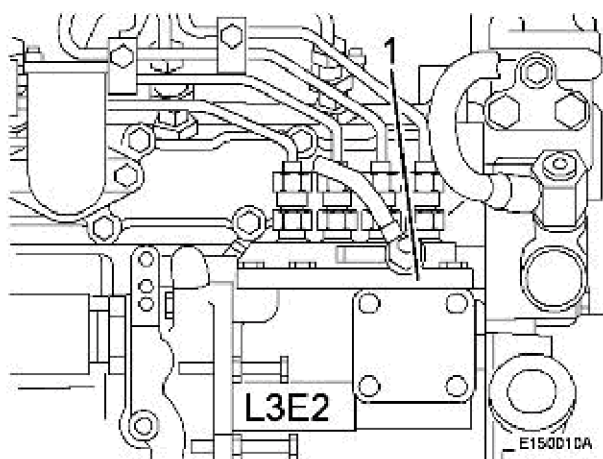

Figure 2

1. Serial number

The serial number is stamped on the engine block near the injection pump mounting bracket.



Construction Equipment

PROSIS Service Information

Document Title : Volvo standard tightening torques	Function Group : 030	Information Type : Service Information	Print Date : 19/10/2011
Profile : CEX, EC15B XTV (Volvo) [GB]			

Volvo standard tightening torques

The tightening torques in the following tables apply for screw connections of the corresponding strength class. If not specified differently, the tables are to be considered as general instructions for the tightening of screw connections.

NOTE For flange bolts of type U6FS the values must be increased by 10%. Screws and nuts must be clean and oiled.



Construction Equipment

PROSIS Service Information

Document Title : Strength class 8.8 Metric coarse and fine threads	Function Group : 030	Information Type : Service Information	Print Date : 19/10/2011
Profile : CEX, EC15B XTV (Volvo) [GB]			

Strength class 8.8 Metric coarse and fine threads

Thread	Nm
M6	10 ± 2
M8	24 ± 5
M10	48 ± 10
M12	85 ± 18
M14	140 ± 25
M16	220 ± 45
M20	430 ± 85
M24	740 ± 150



Construction Equipment

PROSIS Service Information

Document Title : Strength class 10.9 Metric coarse and fine threads	Function Group : 030	Information Type : Service Information	Print Date : 19/10/2011
Profile : CEX, EC15B XTV (Volvo) [GB]			

Strength class 10.9 Metric coarse and fine threads

Thread	Nm
M6	12 ± 2
M8	30 ± 5
M10	60 ± 10
M12	105 ± 20
M14	175 ± 30
M16	275 ± 45
M20	540 ± 90
M24	805 ± 160



Construction Equipment

PROSIS Service Information

Document Title : UNC-threads, coarse pitch	Function Group : 030	Information Type : Service Information	Print Date : 19/10/2011
Profile : CEX, EC15B XTV (Volvo) [GB]			

UNC-threads, coarse pitch

Thread	Nm
1/4"	9 ± 2
5/16"	18 ± 4
3/8"	33 ± 8
7/16"	54 ± 14
1/2"	80 ± 20
9/16"	120 ± 30
5/8"	170 ± 40
3/4"	300 ± 70
7/8"	485 ± 115
1"	725 ± 175



Construction Equipment

PROSIS Service Information

Document Title : Plugs with tapered thread	Function Group : 030	Information Type : Service Information	Print Date : 19/10/2011
Profile : CEX, EC15B XTV (Volvo) [GB]			

Plugs with tapered thread

Size	For aluminium alloys Nm	For ferrous metals Nm
NPTF 1/16	6.4 ± 1	10 ± 2
PT 1/8	10 ± 2	18 ± 3
PT 1/8 NPTF 1/4	10 ± 2	39 ± 5
PT 3/8	-	64 ± 10



Construction Equipment

PROSIS Service Information

Document Title : Engine	Function Group : 030	Information Type : Service Information	Print Date : 19/10/2011
Profile : CEX, EC15B XTV (Volvo) [GB]			

Engine

Tightening torques	Nm
Socket head cap screw M10	78 ± 5
Socket head cap screw M8	24.3 ± 5
Rocker cover bolt	11.3 ± 1.5
Screw of rocker arm bracket	18 ± 3.4
Thermoswitch	22 ± 3.9
Crankshaft pulley nut	107 ± 9.75
Main bearing cap bolt	51.5 ± 2.5
Connecting rod cap nut	33 ± 1.5
Rear plate bolt (tractor engine)	93 ± 10
Flywheel bolt	132 ± 5
Screw for cast iron oil sump	27.5 ± 3
Oil pan drain plug	44 ± 5
Pressure relief valve	49 ± 5
Oil filter	12 ± 1
Oil pressure switch	10 ± 2
Fuel injection pipe nut	29 ± 5
Fuel leak-off pipe nut	27 ± 2.5
Delivery valve holder	44 ± 5
Fuel injection nozzle holder	54 ± 5
Hold-down nut for injection nozzle	37 ± 2.5
Sliding sleeve shaft	35 ± 6
Special nut for torque spring set	20 ± 5
Glow plug	17.2 ± 2.5
Nut for glow plug cable	1.2 ± 0.2
Stop solenoid nut	44 ± 5
Starter B terminal	10.8 ± 1
Nut for rocker arm cover	5.8 ± 1
Injection nozzle holder	54 ± 5
Hold-down nut for injection nozzle	37 ± 2.5
Banjo bolt for injection pump	12 ± 5
Injection pump drain plug	5.8 ± 1
Screw for sheet steel oil sump	11.3 ± 1.5
Bolt for stop plate	10.8 ± 1



Construction Equipment

PROSIS Service Information

Document Title : Mechanical transmission - track gearbox	Function Group : 030	Information Type : Service Information	Print Date : 19/10/2011
Profile : CEX, EC15B XTV (Volvo) [GB]			

Mechanical transmission - track gearbox

Tightening torque	Nm
Plug on cover	46...51
Plug on cover	12...13



Construction Equipment

PROSIS Service Information

Document Title : Hydraulic motor 1 - travel system	Function Group : 030	Information Type : Service Information	Print Date : 19/10/2011
Profile : CEX, EC15B XTV (Volvo) [GB]			

Hydraulic motor 1 - travel system

Tightening torque	Nm
Plug - spool	46...51
Plug control element	12...23
Socket head cap screw - housing	51...65



Construction Equipment

PROSIS Service Information

Document Title : Gear motor for slewing	Function Group : 030	Information Type : Service Information	Print Date : 19/10/2011
Profile : CEX, EC15B XTV (Volvo) [GB]			

Gear motor for slewing

Tightening torque	Nm
Socket head cap screw - housing	85 ± 18



Construction Equipment

PROSIS Service Information

Document Title : Fuels, lubricants and filling capacities (litres)	Function Group : 030	Information Type : Service Information	Print Date : 19/10/2011
Profile : CEX, EC15B XTV (Volvo) [GB]			

Fuels, lubricants and filling capacities (litres)

Only fuels and lubricants complying with the listed specifications may be used.

Use	Quantity	Quality	Viscosity
Fuel tank	26 l		
Engine with oil filter	approx. 3.6 l	API: CD CCMC D2 MIL-L-2104 D MIL-L-46152 B	SAE 15W/40 SAE 10W/30 SAE 10 SAE 30 SAE 40
Hydraulic system	33 l	DIN 51525 H-LP ISO 6743/4 quality HV Hydrelf BIO 46	ISO-VG-68 ISO-VG-46 ISO-VG-32
Travel gear	approx. 2 x 0.33 l	API: GL 4 or GL 5 MIL-L 2105 D	SAE 80W/90 SAE 85W/140 SAE 90 SAE 140
Lubrication grease		ISO 6743/0 quality X	
Engine cooling (Coolant)	approx. 5 l	AFNOR NFR 15-601 BS 6580-BS 5117 ASTM D 3306 SAE J 1034	-25 °C (SUPRA) -37 °C (SUPRA GF)



Construction Equipment

PROSIS Service Information

Document Title : Chapter 2 Engine	Function Group : 030	Information Type : Service Information	Print Date : 19/10/2011
Profile : CEX, EC15B XTV (Volvo) [GB]			

Chapter 2 Engine

Type	EC15B	EC20B
Engine	L3E2-64ESA	
Working principle	Four stroke inline diesel engine, water cooled	
Firing sequence (injection sequence)	1 - 3 - 2	
Compression ratio	23 : 1	
Type of combustion chamber	Swirl chamber	
Weight, kg	125	
Number of cylinders	3	
Bore x stroke, mm	76 x 70	
Displacement, cm ³	952	
Compression pressure	maximum: 32 bar/minimum: 28,5 bar	
Max. permissible pressure deviation between cylinders	3 bar	
Idle speed	1050 + 40 rpm	
Full speed	2300 + 20 rev./min	
Installed net power (ISO 9249)	11.1 kW at 2150 rpm	
Maximum torque	50 kW at 1800 rpm	
Cooling	Centrifugal water pump with temperature control	
Air filter	Dry	

Valve system

Valve clearance (warm or cold engine)	
Intake valve	0,25 mm
Exhaust valve	0,25 mm

Lubrication system

Type	Forced feed (by cycloidal pump)
Oil pressure	3.45 ± 0.5 bar
Oil filter	Paper element (full-flow)

Fuel lift pump

Type	Electrical (diaphragm)
Power at 220 °C and a terminal voltage of 12 V DC	300 cm ³ /min minimum or 400 cm ³ /min maximum

Chapter 2 Engine

Injection pump

Type	Series injection pump
Manufacturer	Bosch NC
Designation	ND-PFR3M
Piston diameter	6.0 mm
Injection delay, degree	4
Pressure valve, type	Silto or Bosch

Injection pump	
Bleeding screw	yes

Injection nozzle	
Type	Throttle pin injection nozzle
Designation	DN 15 PD6
Injection pressure (opening pressure of valve)	140 ± 5 bar



Construction Equipment

PROSIS Service Information

Document Title : Chapter 3 Electrical system	Function Group : 030	Information Type : Service Information	Print Date : 19/10/2011
Profile : CEX, EC15B XTV (Volvo) [GB]			

Chapter 3 Electrical system

System voltage	12 V
----------------	------

Battery	
Quantity	1 unit
Battery disconnecting switch (ground connection)	Connection to negative pole
Voltage	12 V 45 Ah

Starter	
Designation	M2T50381
Type	Displacement by means of electro-magnet CC (with reduction gear)
Rated power, V - kW	12 - 1.6

Alternator	
Designation	AOT25171/AOT25371
Type	IC
Rated power V - A	12 - 40

Glow plug	
Designation	Y-145T
Type	with sheath
Rated voltage V	10.5
Current drain A	9.7 ± 1.0 (30 seconds at rated voltage)

Glow plug relay	
Designation	G71SP
Rated voltage V	12 V DC
Continuous rated power	1 minute
Coil resistance	13

Control clock	
Designation	YM-1C
Eingangsspannungsbereich	9 V-15 V DC
Load	Electro-magnet (coil resistance: min. 1.7)

Chapter 3 Electrical system

Electro-magnet with key switch-off key	
Designation	YMS-1
Type	Solenoid
Coil resistance	1.6 ± 10% at 20 °C
Stroke, mm	10 ± 0.5
Battery voltage, V	9 V-15 V DC

Pre-heating relay	
Designation	G7 1SP
Rated voltage, V	12 V DC
Continuous power	rpm
Coil resistance	13Ω
Inductance	24 mH (at 1 kHz)



Construction Equipment

PROSIS Service Information

Document Title : Chapter 4 Power transmission	Function Group : 030	Information Type : Service Information	Print Date : 19/10/2011
Profile : CEX, EC15B XTV (Volvo) [GB]			

Chapter 4 Power transmission

Travel system			
Type		EC15B	EC20B
Travel speed: slow/fast	XR	2 km/h	-
	XT	2/3.5 km/h	2.7/4.7 km/h
	XTV	2/3.5 km/h	2.7/4.7 km/h
Max. traction power			
Gradability		58% (30°)	
Permissible inclination and cross-slope (50% of the tipping limit)	XR	17.6% (10°)	-
	XT	19% (10°)	25% (14°)
	XTV _{min.}	20% (11°)	
	XTV _{max.}	31% (17°)	

Slewing system		
Type	EC15B	EC20B
Speed of slewing movement	9 rev./min	10 rev./min



Construction Equipment

PROSIS Service Information

Document Title : Chapter 9 Hydraulic system	Function Group : 030	Information Type : Service Information	Print Date : 19/10/2011
Profile : CEX, EC15B XTV (Volvo) [GB]			

Chapter 9 Hydraulic system

Technical data EC15B

Hydraulic pump

Machine	XR	XT	XTV
Bucket cylinder		16/20 l/min	
Boom cylinder		18/14 l/min	
Travel movement left/right		26 l/min.	
Dipper cylinder		22/18 l/min	
Optional equipment		35 l/min.	
Rotation		12 l/min.	
Displacement		12 l/min.	
Dozer blade cylinder		12/16 l/min	
Track width extension	-	-	12/ 16 l/min.

Operating pressure hydraulic circuit

Machine	XR	XT	XTV
Rotation/dozer blade		150 bar	
Bucket/boom/arm/travel system/attachments/dozer blade		155 bar	

Secondary pressure

Machine	XR	XT	XTV
Boom		250 bar	
Dipper		250 bar	
Bucket		250 bar	

Fixed displacement pump

Machine	XR	XT	XTV
Auxiliary circuit		32 bar	

Technical data EC25

Variable displacement load-sensing pump

Machine	XT	XTV
Bucket cylinder	23/31 l/min	
Boom cylinder	23/16 l/min	
Travel movement left/right	26 l/min.	
Dipper cylinder	32/22 l/min	
Optional equipment	40 l/min.	

Machine	XT	XTV
Rotation	15 l/min.	
Displacement	15 l/min.	
Dozer blade cylinder	12/16 l/min	
Track width extension	-	12/16 l/min

Operating pressure hydraulic circuit

Machine	XT	XTV
Rotation/dozer blade	160 bar	
Bucket/boom/arm/travel system/attachments	195 bar	

Secondary pressure

Machine	XT	XTV
Boom	280 bar	
Dipper	280 bar	
Bucket	280 bar	

Fixed displacement pump

Machine	XT	XTV
Auxiliary circuit	32 bar	



Construction Equipment

PROSIS Service Information

Document Title : Chapter 4 Power transmission	Function Group : 030	Information Type : Service Information	Print Date : 19/10/2011
Profile : CEX, EC15B XTV (Volvo) [GB]			

Chapter 4 Power transmission

Travel system			
Type		EC15B	EC20B
Travel speed: slow/fast	XR	2 km/h	-
	XT	2/3.5 km/h	2.7/4.7 km/h
	XTV	2/3.5 km/h	2.7/4.7 km/h
Max. traction power			
Gradability		58% (30°)	
Permissible inclination and cross-slope (50% of the tipping limit)	XR	17.6% (10°)	-
	XT	19% (10°)	25% (14°)
	XTV _{min.}	20% (11°)	
	XTV _{max.}	31% (17°)	

Slewing system		
Type	EC15B	EC20B
Speed of slewing movement	9 rev./min	10 rev./min



Construction Equipment

PROSIS Service Information

Document Title : Chapter 9 Hydraulic system	Function Group : 030	Information Type : Service Information	Print Date : 19/10/2011
Profile : CEX, EC15B XTV (Volvo) [GB]			

Chapter 9 Hydraulic system

Technical data EC15B

Hydraulic pump

Machine	XR	XT	XTV
Bucket cylinder		16/20 l/min	
Boom cylinder		18/14 l/min	
Travel movement left/right		26 l/min.	
Dipper cylinder		22/18 l/min	
Optional equipment		35 l/min.	
Rotation		12 l/min.	
Displacement		12 l/min.	
Dozer blade cylinder		12/16 l/min	
Track width extension	-	-	12/ 16 l/min.

Operating pressure hydraulic circuit

Machine	XR	XT	XTV
Rotation/dozer blade		150 bar	
Bucket/boom/arm/travel system/attachments/dozer blade		155 bar	

Secondary pressure

Machine	XR	XT	XTV
Boom		250 bar	
Dipper		250 bar	
Bucket		250 bar	

Fixed displacement pump

Machine	XR	XT	XTV
Auxiliary circuit		32 bar	

Technical data EC25

Variable displacement load-sensing pump

Machine	XT	XTV
Bucket cylinder	23/31 l/min	
Boom cylinder	23/16 l/min	
Travel movement left/right	26 l/min.	
Dipper cylinder	32/22 l/min	
Optional equipment	40 l/min.	

Machine	XT	XTV
Rotation	15 l/min.	
Displacement	15 l/min.	
Dozer blade cylinder	12/16 l/min	
Track width extension	-	12/16 l/min

Operating pressure hydraulic circuit

Machine	XT	XTV
Rotation/dozer blade	160 bar	
Bucket/boom/arm/travel system/attachments	195 bar	

Secondary pressure

Machine	XT	XTV
Boom	280 bar	
Dipper	280 bar	
Bucket	280 bar	

Fixed displacement pump

Machine	XT	XTV
Auxiliary circuit	32 bar	



Construction Equipment

PROSIS Service Information

Document Title : Recommended lubricants	Function Group : 160	Information Type : Service Information	Print Date : 19/10/2011
Profile : CEx, EC15B XTV (Volvo) [GB]			

Recommended lubricants

Oils

Lubrication chart, unit: Litres

Tank	Fluid	Ambient temperature								EC15B/EC20B	
		-22	-4	14	32	50	68	86	104		122F
		-30	-20	-10	0	10	20	30	40	50°C	Filling capacity
Engine oil sump with oil filter	Engine oil					SAE 30				3.6 l	
		SAE 10W									
		*	SAE 10W-30								
		SAE 15W/40				SAE 40					
Hydraulic oil tank	Hydraulic oil	ISO-VG 32								23 l	
		*	ISO-VG 46								
		ISO-VG 68									
Chain gear, left	Gear oil	*	*SAE 90 and API GL4 or GL5								0.33 l
		SAE 140 and API GL4									
Chain gear, right	Gear oil	SAE 80W-90 and API GL4 or GL5									
		SAE 85W-140 and API GL4 (with limited-slip additive)								0.33 l	
Fuel tank	Diesel oil	ASTM D975 Nr. 1								26 l	
		ASTM D975 No. 2									
Live ring	Grease	*									
		MULTI-PURPOSE #2									-
Cooling system	Longtime coolant	<div style="border: 2px solid red; padding: 5px;">  WARNING! "Longtime coolant", fluorescent yellow colour (COOLELF SUPRA) or fluorescent orange colour (COOLELF SUPRA GF). This coolant must not be mixed with any other type of coolant. </div>								4.5 l	

NOTE *: ex works

ASTM: American Society of Testing and Material
 SAE: Society of Automotive Engineers
 ISO: International Standardization Organization
 API: American Petroleum Institute

- Initial filling: Total filling quantity incl. Oil in components and lines.
- Replenishment: Quantity to top up to maximum level during normal inspection and maintenance.

Caution!

With a sulphur content of less than 0.5% in the diesel fuel the engine oil must be changed in compliance with the maintenance instructions in this manual. With a sulphur content of more than 0.5% the engine oil must be changed according to the following table.

Fuel sulphur content and change intervals

Sulphur content in diesel fuel	Frequency of engine oil change
0.5%... 1.0%	½of the normal interval
More than 1.0%	¼of the normal interval

Caution!

If the machine is started at ambient temperatures of less than 0 °C, engine oil of class SAE 10W, SAE 10W-30 or SAE 15W-40 must strictly be used, even if the temperature will raise to 10 °C or more.

Caution!

According to API engine oil of class CF or CG must be used. If engine oil of class CD is used instead, the change interval must be halved.



Construction Equipment

PROSIS Service Information

Document Title : Measuring conditions	Function Group : 1732	Information Type : Service Information	Print Date : 19/10/2011
Profile : CEX, EC15B XTV (Volvo) [GB]			

Measuring conditions

This chapter explains how to check the performance of hydraulic excavators from Volvo. The following tolerances apply for new machines. Depending on the applicational conditions certain deviations are permissible on used machines. If not specified differently, the measurements must be performed under the following conditions:

- Engine speed: full speed, operating mode "P".
- Hydraulic oil temperature: 50 ± 5 °C.
- Parked: on firm, level ground.

VOLVO

Construction Equipment

PROSIS Service Information

Document Title : Cylinder speed	Function Group : 1732	Information Type : Service Information	Print Date : 19/10/2011
Profile : CEX, EC15B XTV (Volvo) [GB]			

Cylinder speed

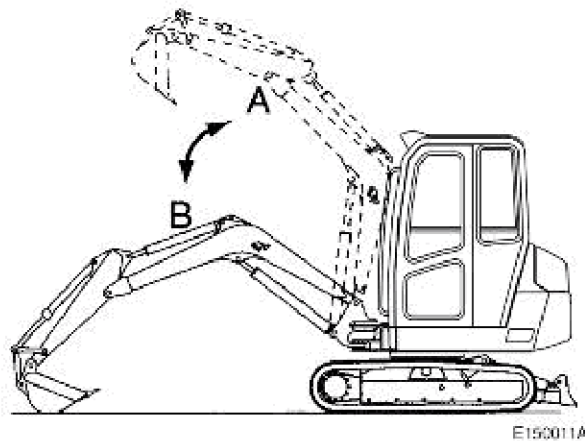

Figure 1
Measuring conditions, boom cylinder

- A. Lifting
- B. Bottom

Preparation

Boom cylinder

- Retract dipper cylinder completely.
- Extend dipper cylinder completely.

Measurement

- Move the control lever against the stop.
- Measure the time the cylinder needs for the full stroke with a stopwatch.
- Perform this measurement three times and calculate the average.

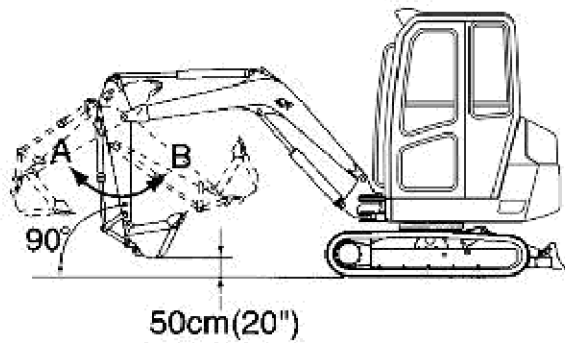

E150012A

Figure 2
Measuring conditions, dipper cylinder

- A. Tipping forward
- B. Tipping back

Dipper cylinder

- Extend dipper cylinder completely.

Measurement

- Move the control lever against the stop.
- Measure the time the cylinder needs for the full stroke with a stopwatch.
- Perform this measurement three times and calculate the average.

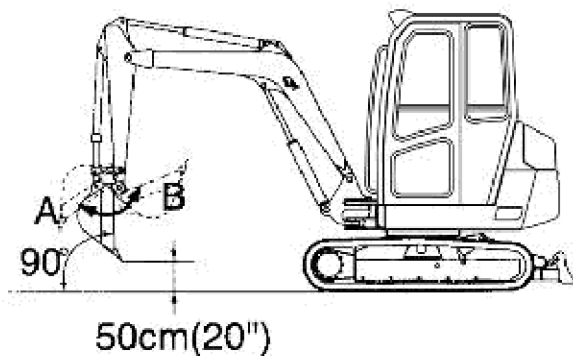

E150013A

Figure 3
Measuring conditions, digger cylinder

- A. Tipping forward
- B. Tipping back

Bucket cylinder

Measurement

- Move the control lever against the stop.
- Measure the time the cylinder needs for the full stroke with a stopwatch.
- Perform this measurement three times and calculate the average.

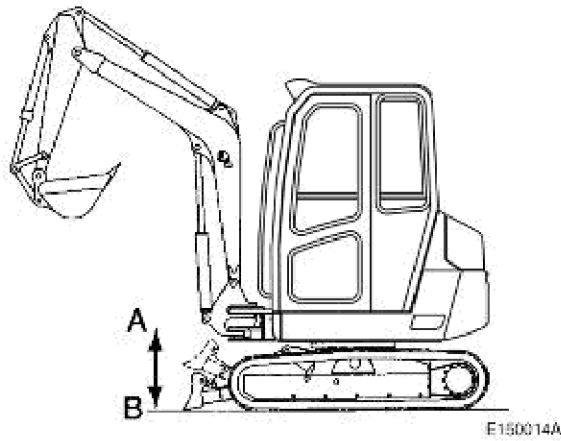

Figure 4
Measuring conditions, dozer blade cylinder

- A. Up
- B. Down

Dozer blade cylinder

Measurement

- Move the control lever against the stop.
- Measure the time the cylinder needs for the full stroke with a stopwatch.
- Perform this measurement three times and calculate the average.

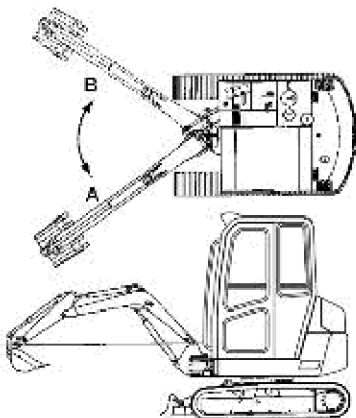

Figure 5
Measuring condition, boom slewing cylinder

- A. Rotation to left
- B. Rotation to right

Boom slewing cylinder

The dipper arm cylinder is fully retracted.
 Extend the bucket cylinder completely.
 Measure the time required for slewing from extreme opposite position to left or right hand end position.

Measurement

- Move the control lever against the stop.
- Measure the time the cylinder needs for the full stroke with a stopwatch.
- Perform this measurement three times and calculate the average.

Cylinder speed, unit: sec.

	Movement	Standard	Permissible value
Boom	Lifting	2.0 ± 0.3	2.5

	Movement	Standard	Permissible value
Dipper	Bottom	2.6 ± 0.3	3.1
	Tipping back	3.1 ± 0.3	3.6
	Tipping forward	2.4 ± 0.3	2.9
Bucket	Tipping back	3.8 ± 0.3	4.3
	Tipping forward	2.4 ± 0.3	2.9
Dozer blade	Up	1.0 ± 0.3	1.5
	Down	1.5 ± 0.3	2.0
Slewing the boom	to left	5.7 ± 0.5	6.7
	to right	4.3 ± 0.5	5.3



Construction Equipment

PROSIS Service Information

Document Title : Creeping of hydraulic cylinders	Function Group : 1732	Information Type : Service Information	Print Date : 19/10/2011
Profile : CEX, EC15B XTV (Volvo) [GB]			

Creeping of hydraulic cylinders

Preparation

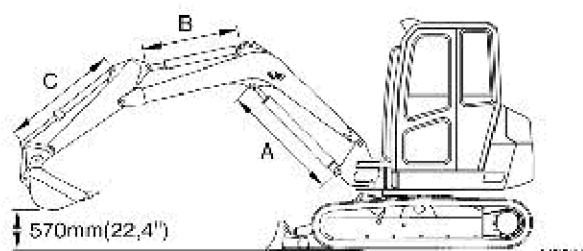

Figure 1
Measuring conditions, creeping

- Bucket fully loaded
- Retract dipper arm cylinder completely
- Extend dipper cylinder completely

Measurement

Measure the distance of the cylinder fastening bolts. Repeat the measurement after 5 minutes and check how far the cylinder:

- has retracted at the boom
- has extended at the dipper
- has retracted at the bucket

Creeping value, unit: mm/5 min.

		Standard	Permissible value	Limit
Boom cylinder	A	Less than 4.0	6.0	8.0
Dipper cylinder	B	Less than 15.0	20.0	30.0
Bucket cylinder	C	Less than 5.0	8.0	10.0



Construction Equipment

PROSIS Service Information

Document Title : Slewing speed	Function Group : 1732	Information Type : Service Information	Print Date : 19/10/2011
Profile : CEX, EC15B XTV (Volvo) [GB]			

Slewing speed

Preparation

- Retract dipper cylinder completely.
- Extend dipper cylinder completely.

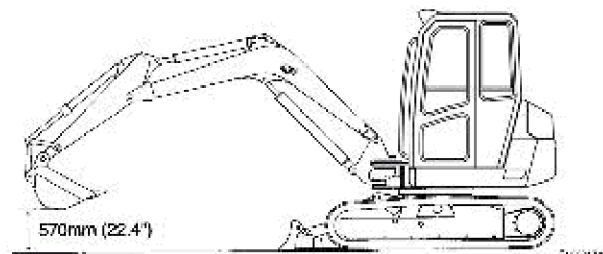

Figure 1
Measuring conditions, slewing speed

Measurement

- Move the slewing gear control lever to the end stop.
- Measure the time the superstructure needs for three full turns at constant speed. (Exclude the first full turn.)
- Measure alternately to by slewing to right and left.

Slewing speed, unit: sec / three revolutions

Standard	Permissible value	Limit
18.4 ± 1.0	21	23

VOLVO

Construction Equipment

PROSIS Service Information

Document Title : Slewing overtravel	Function Group : 1732	Information Type : Service Information	Print Date : 19/10/2011
Profile : CEX, EC15B XTV (Volvo) [GB]			

Slewing overtravel

Preparation

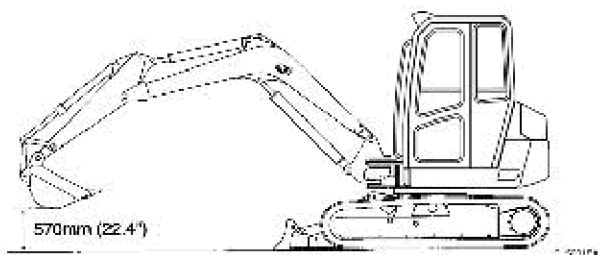

Figure 1
Measuring conditions, slewing speed

- Bucket fully loaded
- Retract dipper arm cylinder completely
- Extend dipper cylinder completely

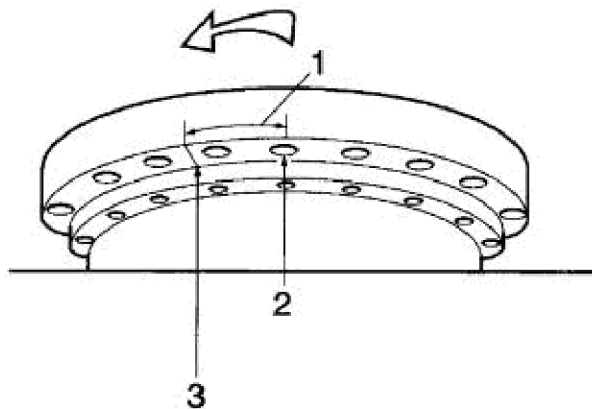

Figure 2
Measure the overtravel

1. Overtravel
 2. Mark on lower frame
 3. Mark on slewing bearing
- Mark the slewing bearing and the lower frame directly underneath.
 - Swivel the superstructure by 180 degrees.

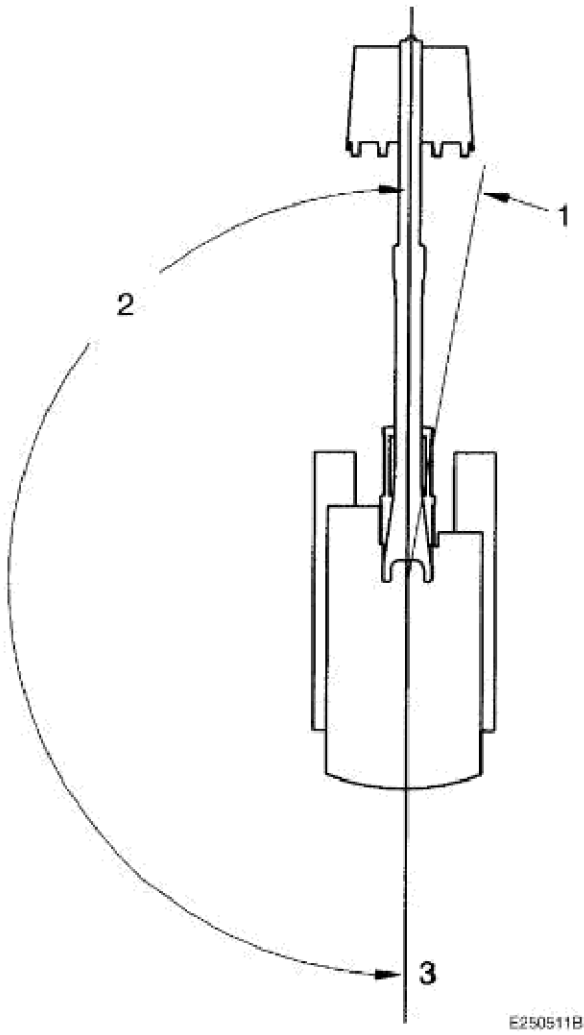

Figure 3
Overtravel

1. Overtravel
2. Swivelling by 180 degrees
3. Start of slewing movement

Measurement

- Move the slewing gear control lever to the end stop and swivel the superstructure by 180 degrees.
- If the marks are right above each other return the lever to neutral.
- Measure the distance between the mark on the live ring bearing and the mark on the lower frame.

Wear limits, unit: mm

	Standard	Permissible value	Limit
Overtravel 1	Less than 430	500	600



Construction Equipment

PROSIS Service Information

Document Title : Measuring the play of the slewing bearing	Function Group : 1732	Information Type : Service Information	Print Date : 19/10/2011
Profile : CEX, EC15B XTV (Volvo) [GB]			

Measuring the play of the slewing bearing

Play of slewing bearing

			Specification
Bearing play in axial direction	Disassembled	Standard	0.15 ~ 0.35 mm
		Permissible play	0.6 mm
	Assembled	Standard	2.0 ~ 4.0 mm
		Permissible play	5.0 mm
Tightening torque	Outer screw		26.7 ± 2.7 Nm
	Inner screw		

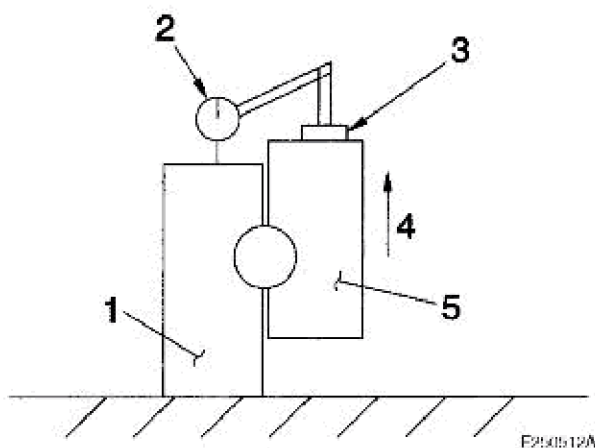

Figure 1
Measure, bearing play (disassembled)

1. Inner race
2. Dial gauge
3. Magnetic stand
4. Movement
5. Outer race

Measurement

Caution!

Before proceeding with the measurement make sure that all fastening screws are properly tightened.

Disassembled

- Lay the live ring on a level surface and attach three magnetic stands to the outer race with distances of 120 degrees to each other.
- Attach three dial gauges to the inner race.
- When pulling the outer race vertically up (4) the axial play complies with the movement between the bearing races.
- Read the values indicated by the dial gauges.

Assembled

Clean the outer race of the live ring and the bottom side of the lower frame.

The live ring is not evenly worn over the entire circumference.

In order to obtain the correct bearing play two measurements are required, whereby the superstructure needs to be swivelled by 90 degrees in between.

1. Measurement

- Align the superstructure to the middle of the lower frame.
- Lower the working attachment to the ground, until the tracks are partly lifted off the ground ([See figure](#)).
- Attach the magnetic stand ([See figure](#)).
- Attach the dial gauge to the bottom side of the superstructure and bring the measuring tip in contact with the underside of the lower frame and set to zero, or vice versa ([See figure](#)).
- Lower the excavator slowly to the ground and maintain the bucket with extended dipper at the height of the cabin floor ([See figure](#)). Read the value indicated by the dial gauge.
- Lower the bucket to the ground again, lift the machine up and check whether the dial gauge has returned to zero.

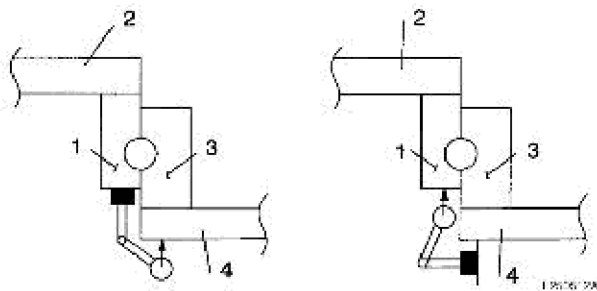
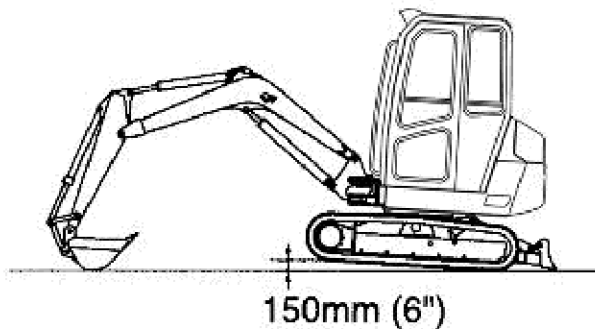

Figure 2
Measurement, bearing play (assembled)

1. Outer race
2. Superstructure
3. Inner race
4. Lower frame



E150018A

Figure 3
Measurement, bearing play (position 1)

2. Measurement

- Turn the superstructure by 90 degrees in relation to the first measurement.
- Measure the play once again using the same method as described for measurement 1.

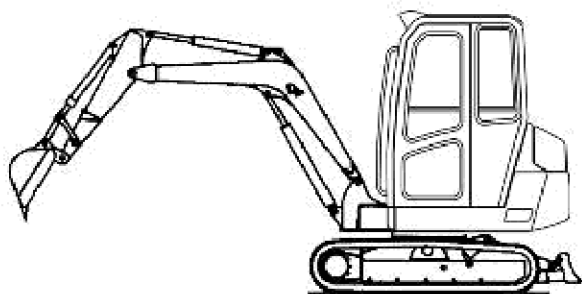

E150020A

Figure 4
Measurement, bearing play (position 2)

Permissible play

Measure the play twice in each position and enter the values into the following table.

Recording the clearance

	Measuring value with superstructure in position 1	Measuring value with superstructure in position 2
A First measurement		
B Second measurement		
Total	A + B	A + B
Mean value	Total/2	Total/2

If there is a big difference between measurements A and B this is most likely caused by a measuring fault. The measurement should therefore repeated several times.

Caution!

The most frequent cause for a failure of the live ring is excessive axial bearing play. For this purpose lubricate the bearing at regular intervals, values see [See further](#) .



Construction Equipment

PROSIS Service Information

Document Title : Travel speed	Function Group : 1732	Information Type : Service Information	Print Date : 19/10/2011
Profile : CEX, EC15B XTV (Volvo) [GB]			

Travel speed

Preparation

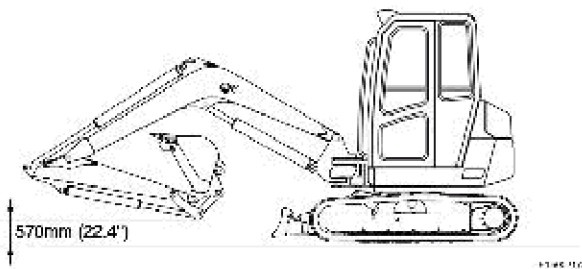

Figure 1
Measuring conditions for travel speed

Measurement

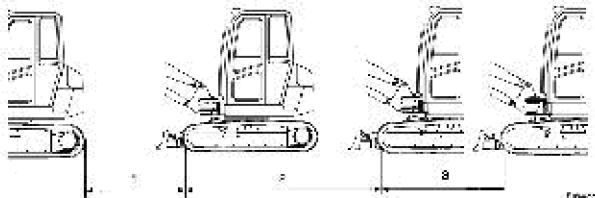
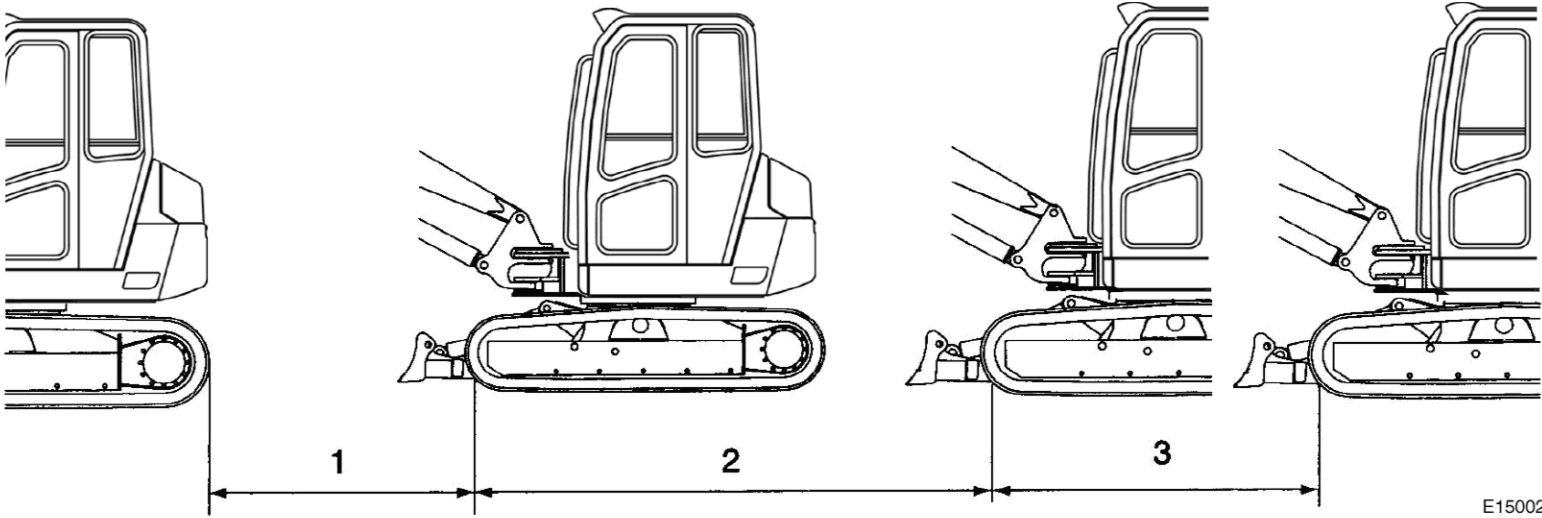

Figure 2
Measurement, travel speed

1. Approximate distance 3 ~ 5 m = travel start before measurement
2. Test distance 20 m
3. Approximate distance 3 ~ 5 m = overtravel after measurement

Permissible limit value: sec / 20 m

		Travel time		
		Standard	Permissible value	Limit
1. Gear	Steel	30 ± 2.0	34	36
	Rubber	27.7 ± 2.0	32	34
2. Gear	Steel	17.6 ± 2.0	22	24
	Rubber	16.3 ± 2.0	20	22





Construction Equipment

PROSIS Service Information

Document Title : Track travel speed	Function Group : 1732	Information Type : Service Information	Print Date : 19/10/2011
Profile : CEX, EC15B XTV (Volvo) [GB]			

Track travel speed

Preparation

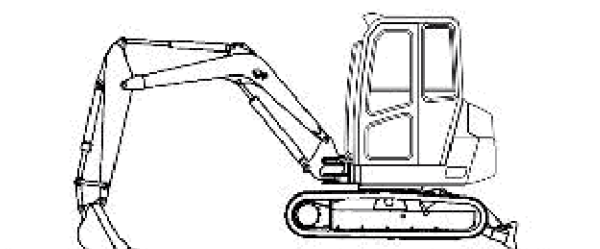

E150 0234

Figure 1
Measuring conditions, track travel speed

- Mark one of the bottom plates on the side at which the test is to be performed.
- Raise the track to be tested off the ground.

Measurement

- Accelerate the engine to full speed.
- Measure the time the track needs to perform three full revolutions. (Exclude the first revolution.)
- Perform this test on both tracks, in both forward and reverse.

Permissible limit value, track travel speed, unit: sec./3 revolutions

		Running time		
		Set value	Permissible value	Limit
1. Gear	Left	26 ± 2.0	30	32
	Right			
2. Gear	Left	15 ± 2.0	19	21
	Right			



Construction Equipment

PROSIS Service Information

Document Title : Deviation when travelling straight ahead	Function Group : 1732	Information Type : Service Information	Print Date : 19/10/2011
Profile : CEX, EC15B XTV (Volvo) [GB]			

Deviation when travelling straight ahead

Preparation

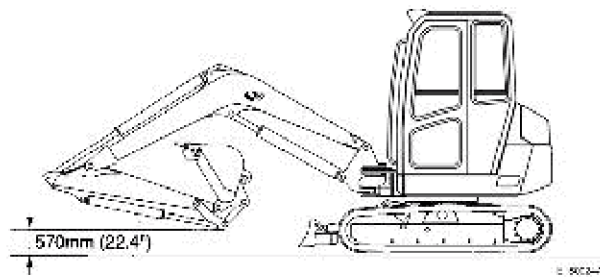

Figure 1
Measuring conditions, deviation when travelling straight ahead

- Fully extend the dipper and bucket cylinders.
- Bring the working attachment to travel position.

Measurement

- Move both travel levers simultaneously to the end stop.
- Measure the distance between the imaginary connecting line of both machine positions and line B.
- Repeat the measurement three times and calculate the mean value.
- Swivel the superstructure by 180 degree and repeat the measurement when driving in reverse.

Permissible limit value, deviation when travelling straight ahead, unit: mm (in)

	Standard	Permissible value	Limit
Deviation distance B	Less than 200	300	400

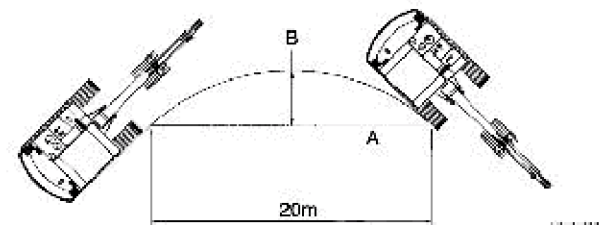
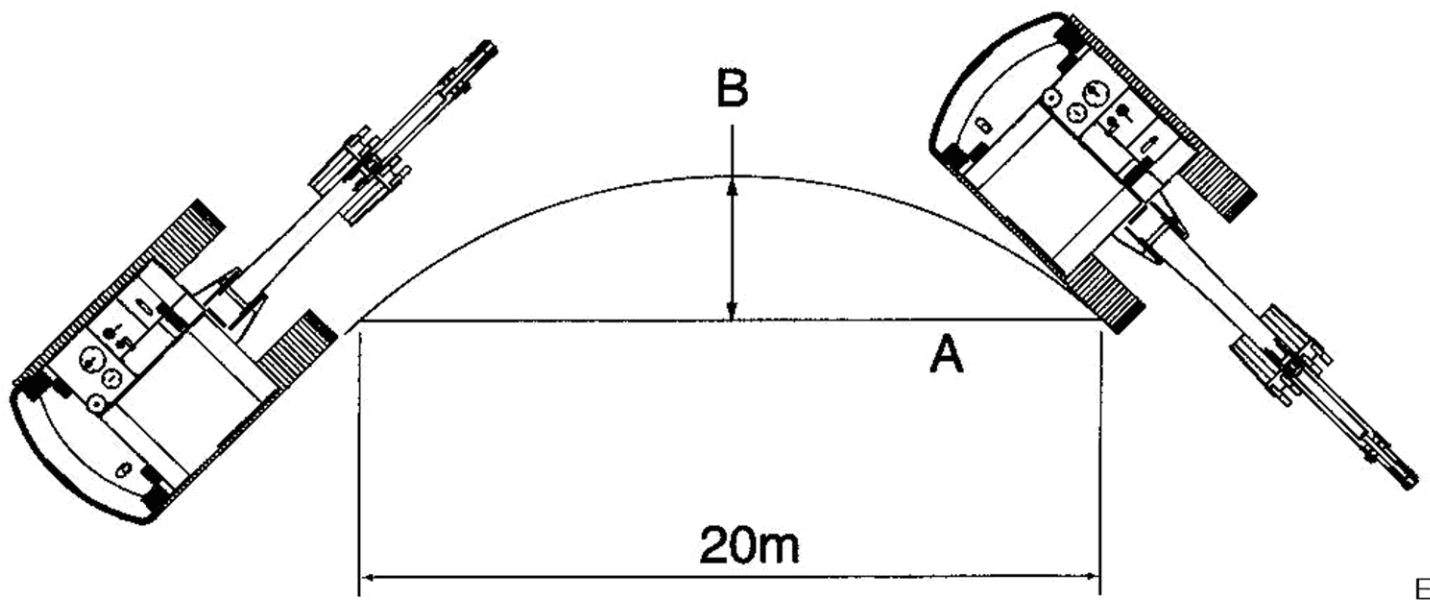

Figure 2
Deviation when travelling straight ahead



E250520A

VOLVO

Construction Equipment

PROSIS Service Information

Document Title : Starting the engine with jump wires	Function Group : 1763	Information Type : Service Information	Print Date : 19/10/2011
Profile : CEX, EC15B XTV (Volvo) [GB]			

Starting the engine with jump wires

Before connecting the jump wires check the following:

- Jump wires and pole clamps must be appropriately dimensioned for the size of the battery.
- Check cables and clamps for damage, corrosion etc.
- Make sure that cables and clamps are tightly connected.
- Leave the starter switch in "OFF"-position (both machines).
- The battery of the running engine must have the same capacity as the battery for the engine requiring jump starting.
- When starting from another machine make sure that the machines will not touch each other.

Connect the jump wires as follows:

- Connect clamp (1) of jump wire (A) with the positive pole (+) of the machine to be jump started.
- Connect clamp (2) with the positive pole (+) of the battery on the machine with the running engine.
- Connect clamp (3) of the jump wire (B) with the negative pole (-) of the battery on the machine with the running engine.
- Connect clamp (4) with the superstructure of the machine to be jump started.

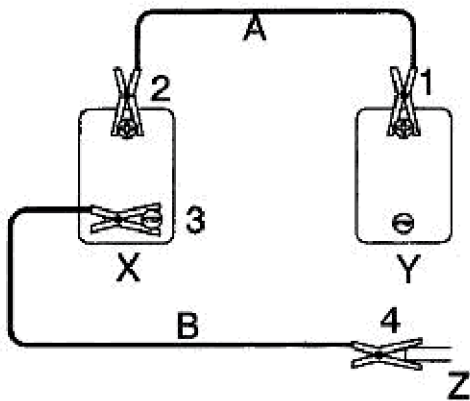

Figure 1
Connection, jump wires

Caution!

Make sure that the clamps are tightly connected with the battery poles. Start the engine with the fully charged battery, then start the engine that needs to be jump started.

When connecting the cables make sure that the positive (+) and the negative (-) poles do not touch.

Caution!

Make sure that the jump wires are correctly connected. Connect the jump wire to the engine block, as far away from the battery as possible. Once the engine has started the jump wires must be removed in reverse order.

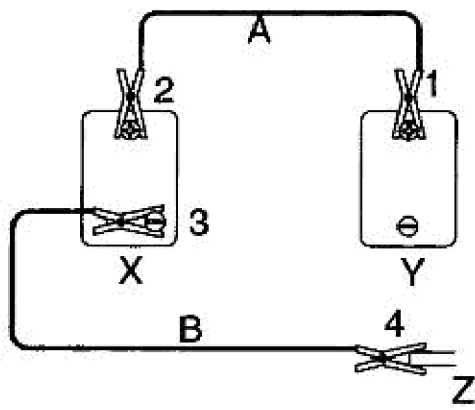

E250522A

Figure 2
Disconnection, jump wires

Start the engine

- Turn the ignition switch to position "START" and start the engine.
- Start the engine for max. 30 seconds. Wait 2 minutes between two starting attempts.
- Once the engine has started the jump wires must be removed in reverse order.

Disconnect the cables as follows:

- Disconnect clamp (4) of jump wire (B) from the superstructure.
- Disconnect clamp (3) from the negative (-) pole of the battery for the running engine.
- Disconnect clamp (2) of jump wire (A) from the positive pole (+) of the running engine.
- Disconnect clamp (1) from the positive pole (+) of the battery for the engine that had to be jump started.



Construction Equipment

PROSIS Service Information

Document Title : Description	Function Group : 200	Information Type : Service Information	Print Date : 19/10/2011
Profile : CEX, EC15B XTV (Volvo) [GB]			

Description

The EC15/EC20B is powered by a water-cooled 3-cylinder four-stroke inline diesel engine with water cooling.

VOLVO

Construction Equipment

PROSIS Service Information

Document Title : Operator side	Function Group : 200	Information Type : Service Information	Print Date : 19/10/2011
Profile : CEX, EC15B XTV (Volvo) [GB]			

Operator side

Figure 1
Engine, side view

1. Oil filler neck
2. Injection pump
3. Water pump
4. Oil filler neck
5. Crankshaft pulley
6. Oil filter
7. Oil drain plug
8. Oil dipstick
9. Flywheel
10. Coolant drain plug
11. Intake manifold
12. Injection nozzle



E250004A

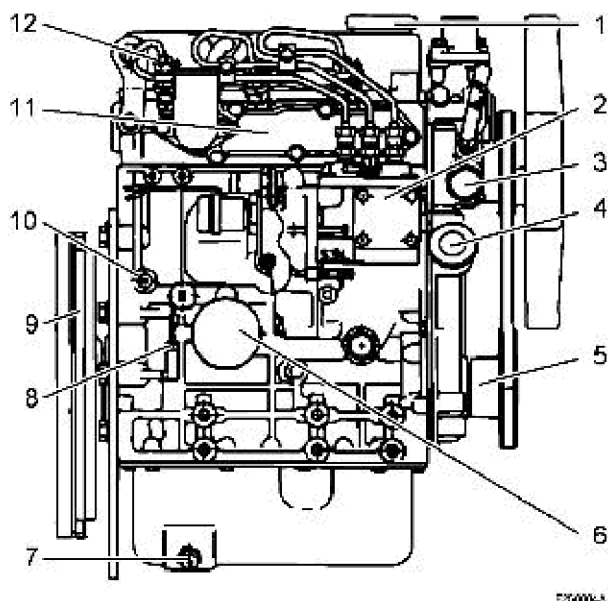
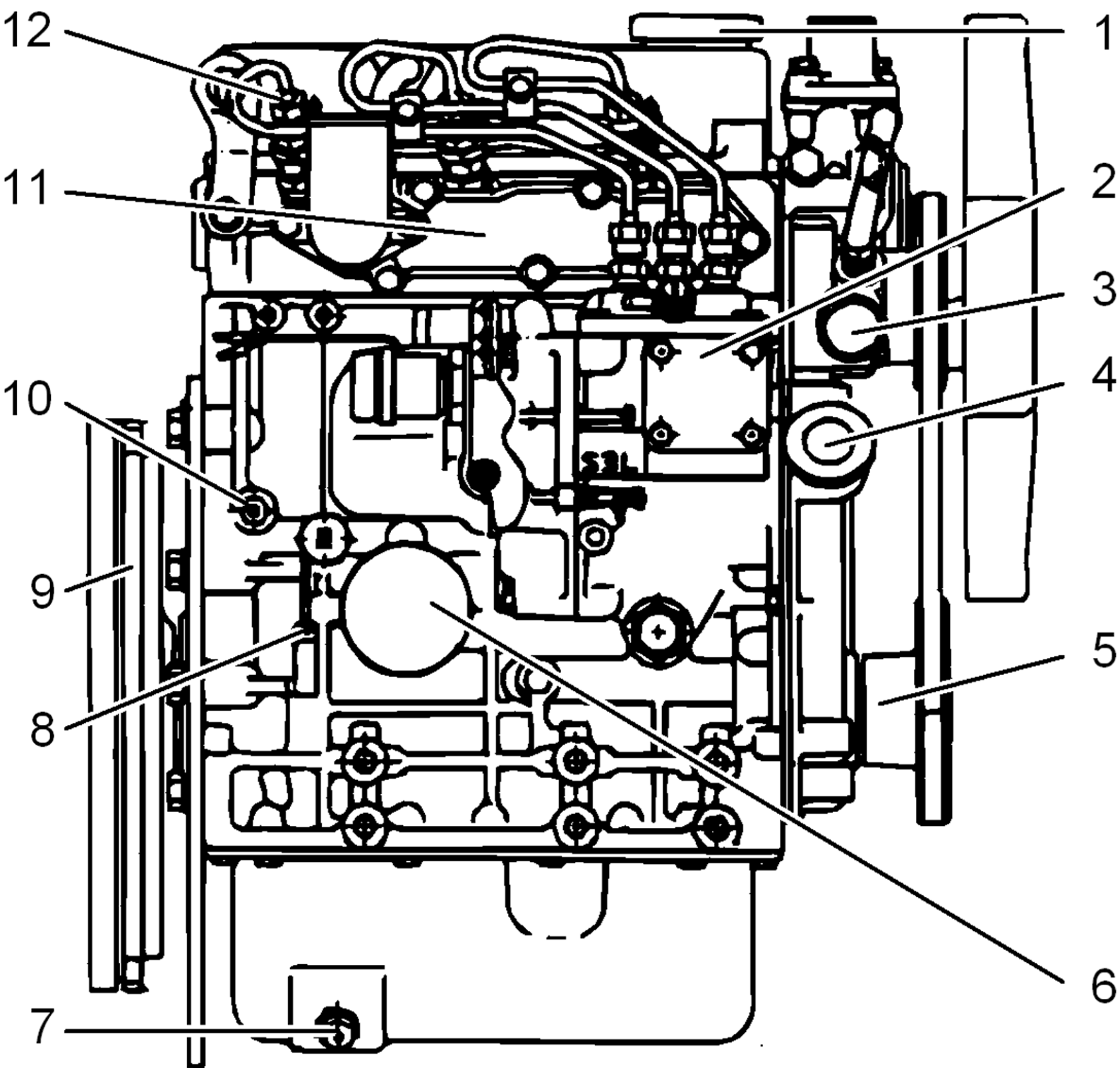

Construction Equipment

PROSIS Service Information

Document Title : Starter side	Function Group : 200	Information Type : Service Information	Print Date : 19/10/2011
Profile : CEX, EC15B XTV (Volvo) [GB]			

Starter side

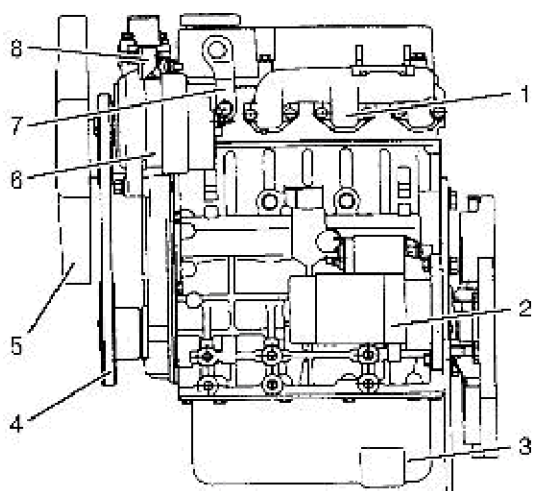

26500234

Figure 1
Engine, side view

1. Exhaust manifold
2. Starter
3. Oil sump
4. V-belt
5. Fan
6. Generator
7. Lifting eye
8. Thermostat

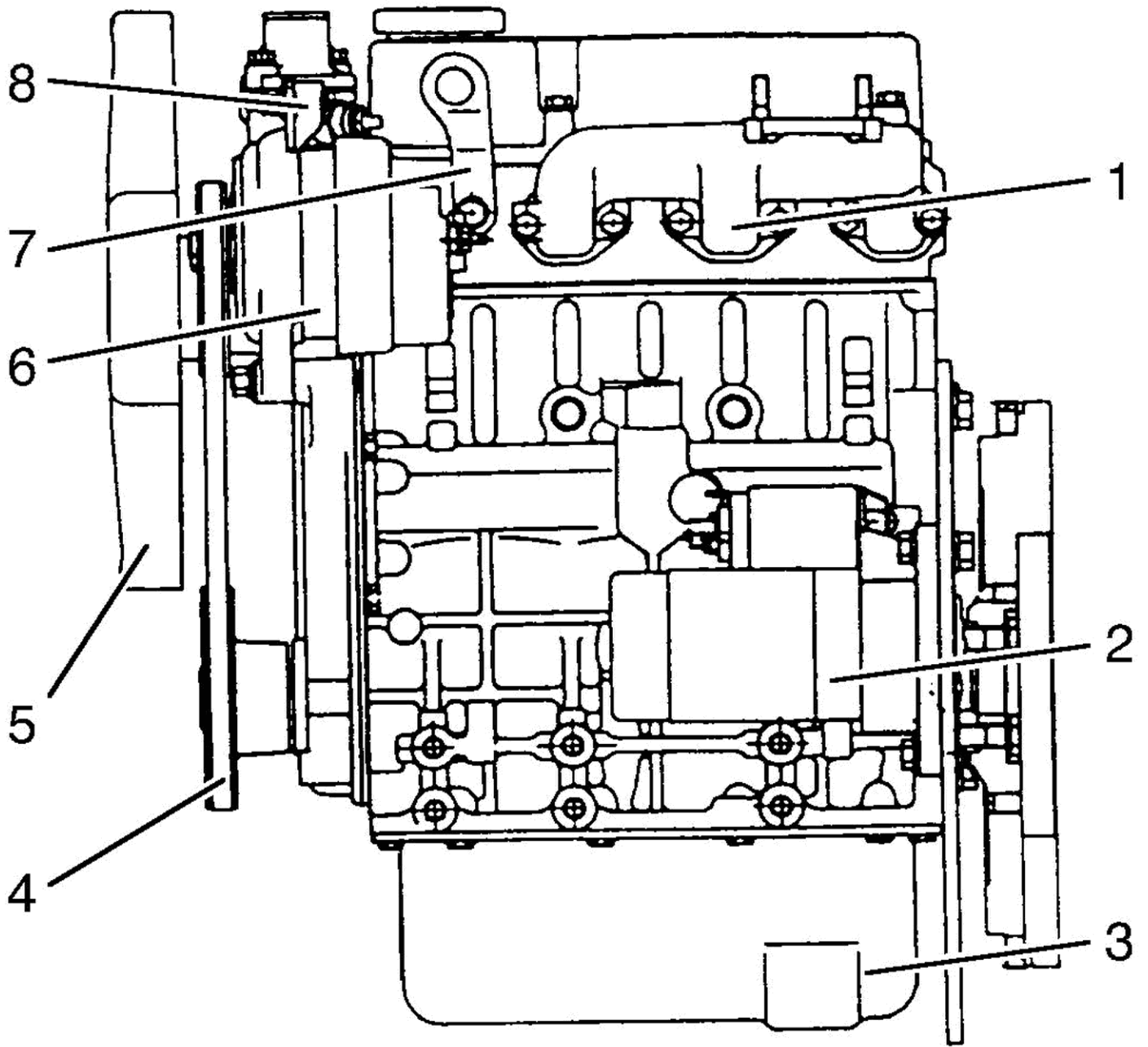



Construction Equipment

PROSIS Service Information

Document Title : Performance characteristics (measuring values for one hour with fan)	Function Group : 200	Information Type : Service Information	Print Date : 19/10/2011
Profile : CEX, EC15B XTV (Volvo) [GB]			

Performance characteristics (measuring values for one hour with fan)

Engine performance diagram

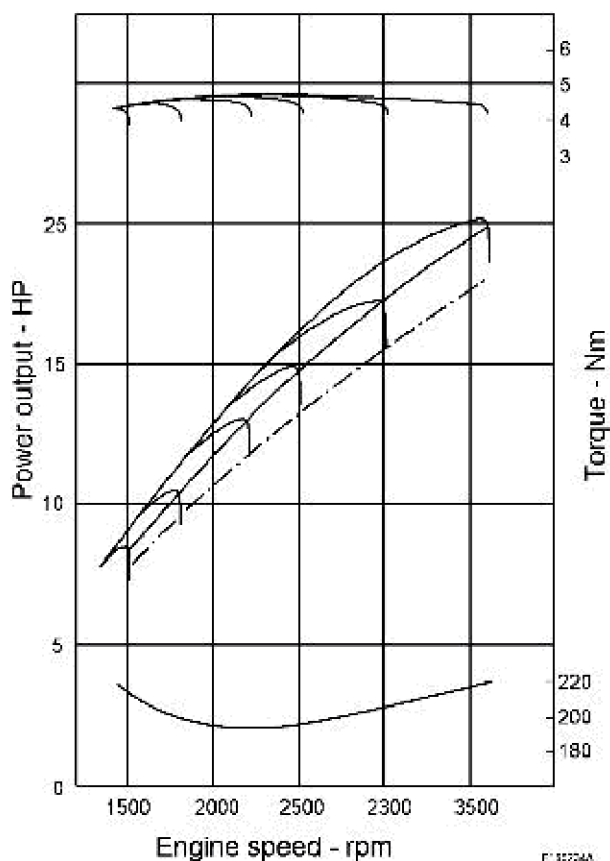

Figure 1



Construction Equipment

PROSIS Service Information

Document Title : Specification, weight	Function Group : 200	Information Type : Service Information	Print Date : 19/10/2011
Profile : CEX, EC15B XTV (Volvo) [GB]			

Specification, weight

Engine, standard	125 kg
------------------	--------



Construction Equipment

PROSIS Service Information

Document Title : Specification, filling capacities	Function Group : 200	Information Type : Service Information	Print Date : 19/10/2011
Profile : CEX, EC15B XTV (Volvo) [GB]			

Specification, filling capacities

Engine, oil change incl. filter	3.6 l
---------------------------------	-------



Construction Equipment

PROSIS Service Information

Document Title : Specification, engine	Function Group : 200	Information Type : Service Information	Print Date : 19/10/2011
Profile : CEX, EC15B XTV (Volvo) [GB]			

Specification, engine

Type	EC15B	EC20B
Engine	L3E2-64ESA	
Working principle	Four stroke inline diesel engine, water cooled	
Firing sequence (injection sequence)	1 - 3 - 2	
Compression ratio	23:1	
Type of combustion chamber	Swirl chamber	
Number of cylinders	3	
Bore x stroke, mm	76 x 70	
Displacement, cm ³	952	
Compression pressure	32 bar	
Max. permissible pressure deviation between cylinders	3 bar	
Idle speed	1050 + 40 rpm	
Full speed	2300 + 20 rpm	
Installed net power (ISO 9249)	1.1 kW at 2150 rpm	
Maximum torque	50 kW at 1800 rpm	
Cooling	Centrifugal water pump with temperature control	
Air filter	Dry	



Construction Equipment

PROSIS Service Information

Document Title : Tightening torque	Function Group : 200	Information Type : Service Information	Print Date : 19/10/2011
Profile : CEX, EC15B XTV (Volvo) [GB]			

Tightening torque

Tightening torques engine L3E2-64ESA

Tightening torques	Nm
Socket head cap screw M10	78 ± 5
Socket head cap screw M8	24.3 ± 5
Rocker cover bolt	11.3 ± 1.5
Screw of rocker arm bracket	18 ± 3.4
Thermoswitch	22 ± 3.9
Crankshaft pulley nut	107 ± 9.75
Main bearing cap bolt	51.5 ± 2.5
Connecting rod cap nut	33 ± 1.5
Flywheel bolt	132 ± 5
Screw for cast iron oil sump	27.5 ± 3
Oil pan drain plug	44 ± 5
Pressure relief valve	49 ± 5
Oil filter	12 ± 1
Oil pressure switch	10 ± 2
Fuel injection pipe nut	29 ± 5
Fuel leak-off pipe nut	27 ± 2.5
Delivery valve holder	44 ± 5
Fuel injection nozzle holder	54 ± 5
Hold-down nut for injection nozzle	37 ± 2.5
Sliding sleeve shaft	35 ± 6
Special nut for torque spring set	20 ± 5
Glow plug	17.2 ± 2.5
Nut for glow plug cable	1.2 ± 0.2
Stop solenoid nut	44 ± 5
Starter B terminal	10.8 ± 1
Nut for rocker arm cover	5.8 ± 1
Injection nozzle holder	54 ± 5
Hold-down nut for injection nozzle	37 ± 2.5
Banjo bolt for injection pump	12 ± 5
Injection pump drain plug	5.8 ± 1
Screw for sheet steel oil sump	11.3 ± 1.5
Bolt for stop plate	10.8 ± 1



Construction Equipment

PROSIS Service Information

Document Title : Valve timing	Function Group : 200	Information Type : Service Information	Print Date : 19/10/2011
Profile : CEX, EC15B XTV (Volvo) [GB]			

Valve timing

Technical data, general

Valve system	
Valve clearance (warm or cold engine)	
Intake valve	0.25 mm
Exhaust valve	0.25 mm



Construction Equipment

PROSIS Service Information

Document Title : Engine trouble shooting	Function Group : 200	Information Type : Service Information	Print Date : 19/10/2011
Profile : CEX, EC15B XTV (Volvo) [GB]			

Engine trouble shooting

Engine faults must be detected and rectified as quickly as possible in order to avoid more expensive repairs. The following table summarizes the most important faults and their rectification.

Problem/fault	Possible cause of fault	Fault remedy
Engine does not start	Starter switch defective	Tighten connections. Replace the switch.
	Starter power too low	If the starter is OK, check condition of battery and electric connections.
	Air in fuel system	Bleed the system.
	Air filter dirty	Replace the air filter.
	Wrong oil viscosity	Check viscosity and fill in correct oil.
	Engine too cold	Check the function of the preheater plug.
	Injection valves defective	Check and adjust the injection valves Replace defective valves.
	Incorrect injection timing	Adjust the injection timing. Check the valve clearance.
Engine shuts down automatically	Compression pressure too low	Check condition of cylinder head gasket, valves and piston rings.
	Fuel tank empty	Fill in fuel.
	Air in fuel system	Bleed the fuel system.
	Fuel filter dirty	Clean or replace the fuel filter.
	Fuel pump defective	Check connection of fuel pump or replace fuel pump.
Erratic running of engine	Exhaust system clogged	Clear or replace the exhaust system.
	Fuel pump defective	Replace the pump.
	Fuel filter dirty	Clean or replace the fuel filter. Bleed the fuel system.
	Air filter dirty	Clean the air filter. Check the intake air.
Engine overheating	Injection valves defective	Check and adjust the injection valves Replace defective valves.
	Cooling system elements defective	Check elements (water pump, radiator, thermostat, cylinder head gasket, coolant hoses).
	Fan not running	Check presence, tension and cleanliness of V-belt.
	Lubrication system elements defective	Check elements (oil filter, oil pump, suction filter) and replace defective parts.
	Incorrect injection timing	Adjust the injection timing. Check the valve clearance.
	Oil level too low	Fill in oil. Check whether the oil in the engine meets the operating conditions.
	Governor incorrectly adjusted	Adjust the governor.
Engine develops black smoke	Coolant level not correct	Correct the coolant level. Check whether the coolant meets the operating conditions.
	Air cleaner soiled	Clean or replace the air filter.
	Poor fuel quality	Check quality of fuel and suitability for climatic conditions.

Problem/fault	Possible cause of fault	Fault remedy
	Valve clearance and injection timing not correct	Adjust valve clearance and injection timing.
	Compression pressure not O.K.	Check condition of cylinder head gasket, valves and piston rings.
	Injection pressure not O.K.	Check and adjust the injection valves
	Injection pump defective	Check injection pump, replace if necessary.
Irregular idle speed	Engine control cable incorrectly adjusted	Adjust the control cable.
	Poor engine oil quality	Fill in oil as required for the operating conditions.
	Poor fuel quality	Check quality of fuel and suitability for climatic conditions.
	Valve clearance and injection timing not correct	Adjust valve clearance and injection timing.
	Opening pressure of injection valves not correct	Check opening pressure and injection valves.
	Compression pressure not O.K.	Check condition of cylinder head gasket, valves and piston rings.
	Injection pump defective	Check injection pump, replace if necessary.
Unusual engine noise	Poor fuel quality	Check quality of fuel and suitability for climatic conditions.
	Air cleaner soiled	Clean or replace the air filter.
	Incorrect injection timing	Adjust the injection timing.
	Engine shut-down solenoid not O.K.	Check the engine shut-down solenoid.
	Injection pressure not O.K.	Adjust the injection valves.
	Compression pressure not O.K.	Check condition of cylinder head gasket, valves and piston rings.
Oil pressure too low	Injection pump defective	Replace the injection pump.
	Oil level and oil quality not correct	Check oil level and oil quality and fill in specified oil.
Battery charge condition too low	Oil pressure switch defective	Check and replace the oil pressure switch.
	Fan V-belt too loose	Tighten the V-belt and replace a defective V-belt.
	Generator defective	Check and replace the generator.
	Battery defective	Replace the battery.
Engine cannot be shut down	Wiring not O.K.	Check correct connection of cables.
	Regulator defective	Check regulator, replace if necessary.
Engine cannot be shut down	Starter switch defective	Tighten connections. Replace the switch.
	Engine shut-down solenoid not O.K.	Check the engine solenoid, replace if necessary.

VOLVO

Construction Equipment

PROSIS Service Information

Document Title : Removing the engine	Function Group : 200	Information Type : Service Information	Print Date : 19/10/2011
Profile : CEX, EC15B XTV (Volvo) [GB]			

Removing the engine

Op nbr 2101

[Lifting sling 1 m](#)
[Shackle 3/8"](#)

**WARNING!**

Disconnect and connect the battery only with the ignition switched off. Disconnect the minus pole (green fastening) first. During assembly connect the plus pole (red cable) first.

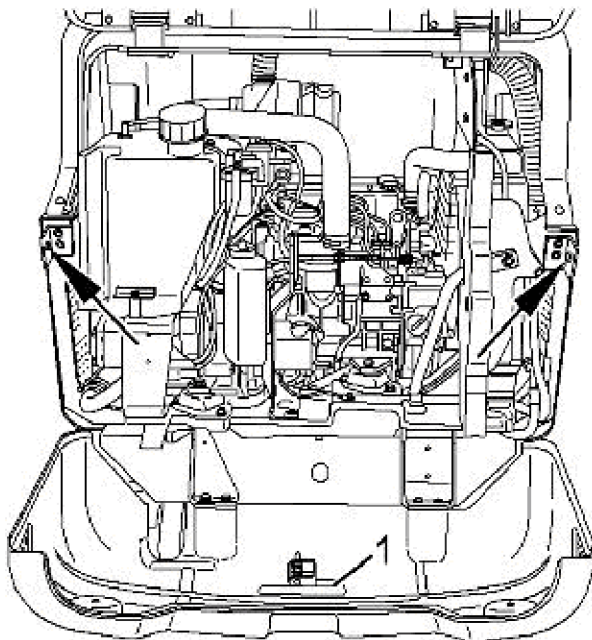
**Figure 1**

- Disconnect the ground cable from the battery.
- Unscrew both screws (arrows) on both sides of the counterweight.
- Pull safety lever (1) and move the counterweight to bottom position.

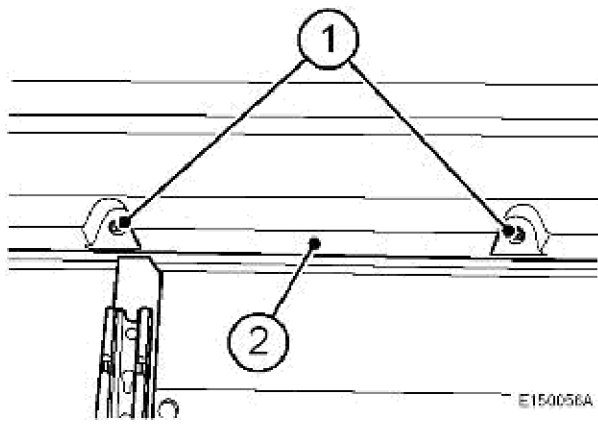

Figure 2

- Unscrew the front socket head cap screws (1) for the hood (2).

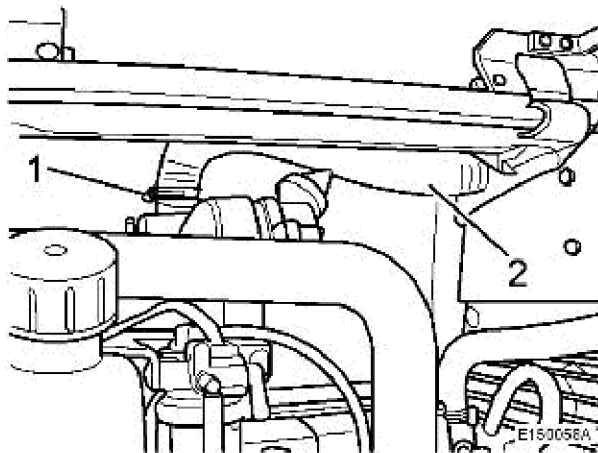

Figure 3

- Loosen hose clamp (1) and place the stop hose (2) to the side.

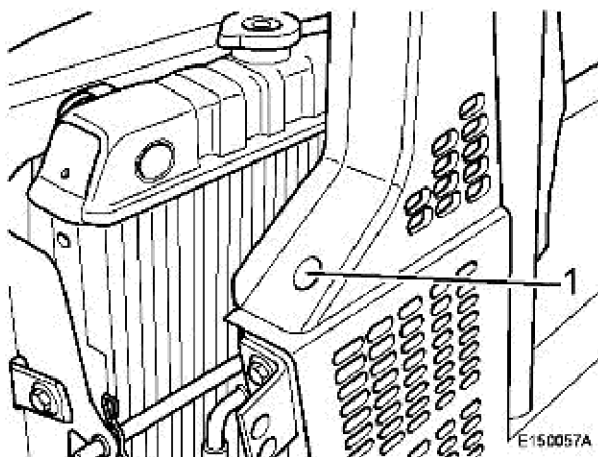
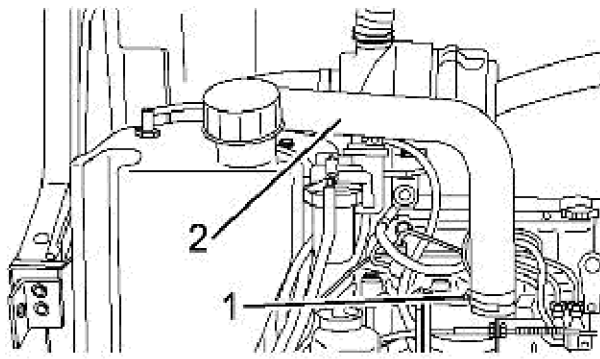

Figure 4

- Unscrew both rear socket head cap screws (1) and take off hood with engine hood.



E150059A

Figure 5

- Loosen hose clamp (1) and pull air intake hose (2) off the air intake pipe.
- Close openings on the engine with adhesive tape.
- Disconnect all necessary electrical cables and terminals from the following components:
 - Air filter contamination indicator
 - Fuel sensor
 - Glow plug
 - Engine shut-down solenoid
 - Plug for hand lamp
 - Temperature switch
 - Ground strap on engine and engine carrier
- Remove the fastening clamps for engine cable set.

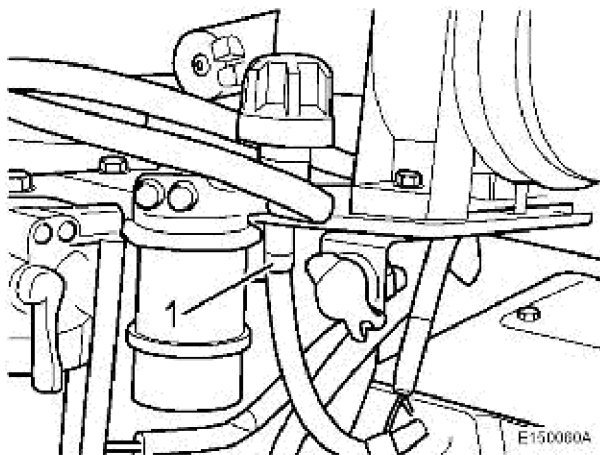

E150060A

Figure 6

- Remove the breather line (1) from the hydraulic oil tank.

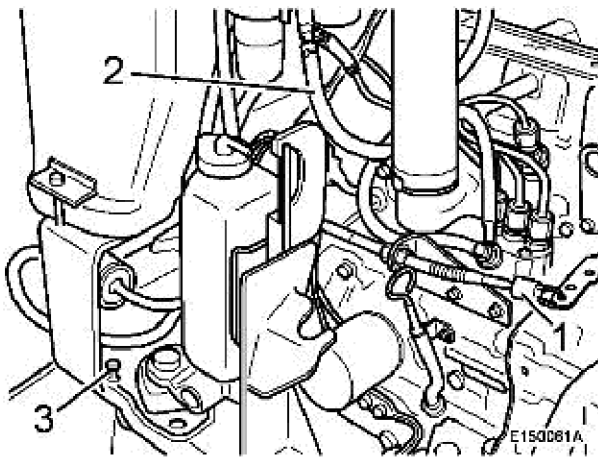

Figure 7

- Unhook throttle cable (1) from the injection pump.
- Disconnect fuel supply line (2).
- Unscrew all screws (3) from the fuel tank.
- Remove fuel tank, filter and air filter as one unit.

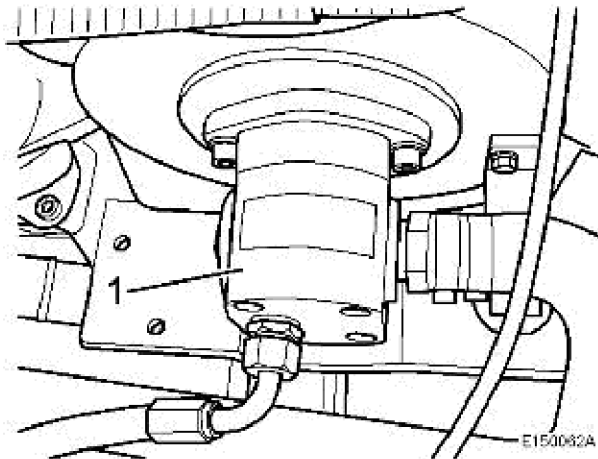

Figure 8

- Disassemble hydraulic pump (1) from engine, lay to the side and fasten it safely.

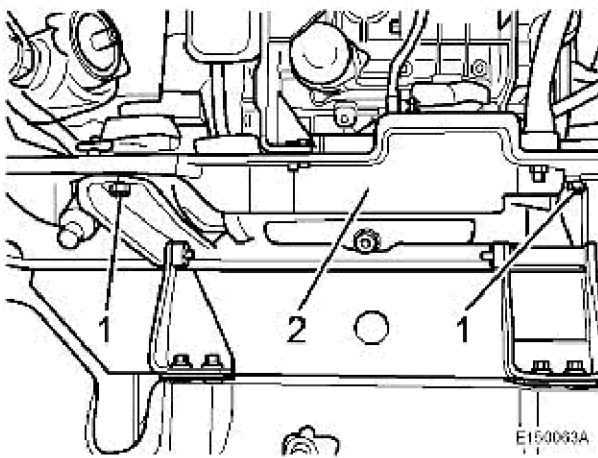

Figure 9

- Unscrew fastening screws (1) for engine carrier (2).